

**PARSUN OUTBOARD ENGINE
SERVICE MANUAL**

F15/F9.9BM(F15/F9.9W)

SUZHOU PARSUN POWER MACHINE CO., LTD.

NOTICE

This manual includes service instructions for F9.9, F15 and has been prepared by Parsun Power primarily for use by the dealers when performing maintenance and repair to Parsun outboard engines. Before performing maintenance, please read the manual carefully. When performing maintenance and repair to Parsun outboard engines, please use the service procedure and tools recommended by the manual. If you use other service procedure and tools, please follow guidance from experienced maintenance people, to avoid damage to people and outboard engines.

The manual is based on the sample machines that are produced at the time of printing, so the model being actual purchased may differ a little from the descriptions and illustrations given in this manual. If necessary, our company will distribute the manual revision to dealers.

In this Service Manual, particularly important information is distinguished in the following ways, please read the manual carefully, and perform the instructions correctly and carefully.

WARNING:

Failure to follow WARNING instructions could result in severe injury or death to the machine operator and bystander.

CAUTION:

A CAUTION indicates special precautions that must be taken to avoid damage to the outboard motor.

NOTE:

A NOTE provides key information to make procedures easier or clearer.

The common troubles and solutions are given in the end of the manual, please read carefully. When performing maintenance and repair to Parsun outboard engines, they will help you judge the outboard engine's status quickly and improve the work efficiency.

All rights reserved.

This manual cannot be reproduced or transmitted in any form or by any means without the written approval of our company.

Suzhou Parsun Power Machine Co., Ltd.

INDEX

GENERAL INFORMATION	1
IDENTIFICATION	1
PROPELLER SELECTION	1
EMERGENCY START	1
SAFETY WHILE WORKING	2
DISASSEMBLY AND ASSEMBLY	3
ONE-TIME USE PARTS	4
PRE-DELIVERY CHECK	4
SPECIAL TOOLS AND DETECTION DEVICE	6
EXPLOSIVE DRAWING AND SYMBOL	8
SPECIFICATIONS	9
OUTBOARD ENGINE SPECIFICATIONS	9
MAINTENANCE INFORMATION	10
Power unit	10
Lower unit	11
Ignition system	11
Charge system	12
TIGHTENING TORQUE	12
Specified torque	12
General torque	13
PERIODIC SERVICE	14
MAINTENANCE TIME TABLE	14
FUEL SYSTEM	15
POWER UNIT	15
Engine oil level	15
Changing engine oil	16
Valve clearance	16
Spark plug	17
CONTROL SYSTEM	17
Throttle grip	17
Idling speed	18
Start-in-gear protection	19
LOWER UNIT	19
Gear oil	19
Changing gear oil	19
Lower unit leakage check	20
GENERAL INSPECTION	20

Anode	20
Grease points	20
Cooling water passage	21
Thermostat	22
RECOIL STARTER	22
NOTICE	22
EXPLOSIVE DRAWING	23
DISASSEMBLING	27
START ROPE REPLACEMENT	27
DISASSEMBLING AND INSPECTION	28
ASSEMBLING	29
INSTALLATION	29
IGNITION SYSTEM	29
NOTICE	29
EXPLOSIVE DRAWING	30
WIRING DIAGRAM	35
SPARK PLUG IGNITION	35
SPARK PLUG CAP	36
FLYWHEEL MAINTENANCE	36
CDI INSPECTION	36
IGNITION COIL INSPECTION	36
PULSED COIL INSPECTION	37
CHARGE COIL INSPECTION	37
FUEL SYSTEM	38
NOTICE	38
EXPLOSIVE DRAWING	38
THROTTLE CONNECTING ROD ADJUSTMENT	44
FUEL JOINT REMOVAL AND INSPECTION	44
FUEL PUMP REMOVAL AND INSPECTION	44
FILTER INSPECTION	45
POWER UNIT	46
NOTICE	46
EXPLOSIVE DRAWING	46
SPECIAL TOOLS	54
COMPRESSION PRESSURE INSPECTION	54
OIL PRESSURE INSPECTION	55
OIL PRESSURE SWITCH INSPECTION	55

DISASSEMBLING POWER UNIT	55
BELT PULLEY AND TIMING BELT	56
DISASSEMBLING AND INSPECTION	57
CYLINDER COVER	57
Disassembling.....	57
Valve and valve guide bush.....	58
Valve spring.....	58
Valve rocker arm and rocker shaft.....	58
Camshaft.....	58
Oil pump check.....	59
Valve guide bush replacement.....	59
Valve seat inspection.....	60
Valve seat cutting.....	61
Valve installation.....	61
Assembling cylinder cover.....	61
CRANKCASE	61
Disassembling.....	61
Piston.....	62
Cylinder bore.....	62
Piston pin diameter.....	63
Piston ring.....	63
Crankshaft.....	63
Crankpin oil clearance.....	63
Main journal oil clearance.....	64
Cylinder body and crankcase.....	64
FULL INSTALLATION	64
Piston connecting rod installation.....	64
Piston ring installation.....	65
Piston installation.....	65
Crankshaft installation.....	65
Assembling power unit.....	66
UPPER UNIT	68
TOP COWLING	68
Explosive drawing.....	68
Disassembling and inspection.....	69
BOTTOM COWLING	70
Explosive drawing.....	70
Disassembling and inspection.....	74
STEERING HANDLE	75
Explosive drawing.....	75

Disassembling and inspection	78
BRACKET	79
Explosive drawing	79
Disassembling and inspection	83
UPPER UNIT	85
Explosive drawing	85
Disassembling and inspection	86
LOWER UNIT	87
WATER PUMP ASSEMBLY	87
Explosive drawing	87
Disassembling and inspection	88
LOWER UNIT	89
Explosive Drawing	89
Disassembling and inspection	94
Propeller shaft and clutch block	94
Dog clutch installation	95
Lower casing cover	95
Lower casing cover oil seal and bearing installation	95
Drive shaft	96
Shift rod cam	96
Gear	96
Forward gear bearing	96
Lower casing inspection	96
Assembling lower casing	96
Lower unit installation	97
Shim selection	98
COMMON TROUBLES AND SOLUTIONS	99

GENERAL INFORMATION

IDENTIFICATION

The outboard motor serial number is marked on the label. The label can be found on the bracket left assembly or on the upper part of the bracket swivel. Record your outboard motor serial number in the spaces provided to assist you in ordering spare parts from your Parsun dealer or for reference in case your outboard motor is stolen.

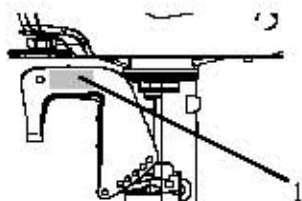

1. Outboard motor serial number location

Serial number as follows:

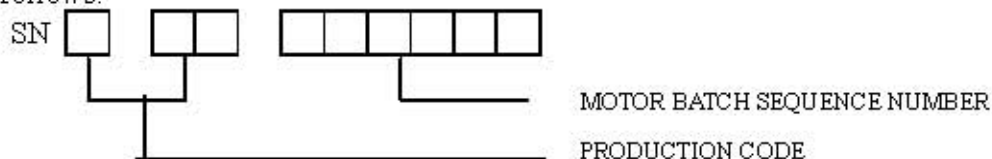

PROPELLER SELECTION

The performance of your outboard motor will be critically affected by your choice of propeller, as an incorrect choice could adversely affect performance.

For a greater boat load and a low engine speed, a smaller-pitch propeller is more suitable. Conversely, a large-pitch propeller is more suitable for a smaller operating load as it enables the correct engine speed to be maintained.

When the engine is running at full throttle position, the suitable propeller should be used according to the engine's RPM and the fuel capability. So the outboard engine can supply the best performance.

Propeller sizes	Material
9 1/4 × 8	Aluminum alloy
9 1/4 × 11	

EMERGENCY START

If the starting device is not working, the engine can be started by emergency start cable.

⚠️WARNING:

- The start program can only be used in emergency and to return to harbor for repairing.
- When you start the engine by emergency start cable, the start-in-gear protection device is not working. So please ensure the shift rod is in NEUTRAL position.
- Please ensure nobody standing behind you in case the cable is pulled out to hurt people.
- After the engine starts up, don't fit the start device or top cowling. Put clothing or other

items far away. Don't touch flywheel or other moving parts.

- When starting and operating, don't touch ignition coil, spark plug cap or other electric parts.

The procedure is as follows:

1. Remove the top cowling.
2. Remove the start-in-gear protection device cable.



1. Start-in-gear protection device cable

3. Demount three bolts and remove starter.



4. Insert the knot of the cable in the notch of flywheel rotor, and wind the cable around flywheel several rounds in clockwise direction.

5. Pull the manual starter handle slowly until you feel resistance.



6. Give a strong pull to start the engine. Repeat if necessary.

SAFETY WHILE WORKING

To prevent the danger or accidents when performing maintenance and repair, and improve the work efficiency, please obey the following safety procedures.

1. FIRE PREVENTION

Gasoline (petrol), lubricant and grease are highly flammable. While working, keep away from heat, sparks and open flames.

2. VENTILATION

Petroleum vapor and engine exhaust gases are violent in toxicity. They are harmful to breathe and deadly if inhaled in large quantities. When test-running an engine indoors, maintain good ventilation.

3. SELF-PROTECTION

Protect your eyes with suitable safety glasses or safety goggles, when drilling, grinding or operating air compressor. Protect hands and feet by wearing protective work clothes, safety gloves and shoes if necessary.

4. LUBRICANTS AND SEALING FLUIDS

When performing maintenance procedures and repair to Parsun outboards, use only products provided or recommended by our Company.

Under normal conditions of use, there should be no hazards from the use of the lubricants mentioned in this manual, but safety is all-important, and by adopting good safety practices, any risk is minimized.

- ① To protect the skin, the application of a suitable barrier cream to the hands before working is recommended.
- ② Clothing which has become contaminated with lubricants should be changed as soon as practicable, and washed before further use.
- ③ Avoid skin contact with lubricants.
- ④ Hands and any other part of the body which have been in contact with lubricants or lubricant-contaminated clothing, should be thoroughly washed with hot water and soap as soon as practicable.
- ⑤ A supply of clean lint-free cloths should be available for wiping run-off lubricants or grease.

5. GOOD WORKING PRACTICES

- ① Follow the tightening torque instruction. When tightening bolts, nuts and screws, tighten the large sizes first, and tighten inner-positioned fixings before outer-positioned ones.
- ② Use the recommended special tools to protect parts from damage. Use the right tool in the right manner.

DISASSEMBLY AND ASSEMBLY

When disassembly and assembly, please follow the following principles:

1. Use special tools when disassembling and assembling.
2. Clean dirt before disassembling the parts.
3. Oil the contact surfaces of moving parts before assembly.
4. Install bearing with the manufacturer's markings on the side exposed to view and liberally oil the bearing.

5. When installing oil seals, apply a light coating of water-resistant grease to the ledge and outside diameter.
6. After assembly, check if the moving parts operate normally.

ONE-TIME USE PARTS

One-time use parts are gasket, oil seal, O-ring, cotter pin and spring, ring, and etc.. When re-assembling outboard engine, you must change the one-time use parts.

PRE-DELIVERY CHECK

To ensure the using, please inspect the following before delivery.

1. CHECKING FUEL SYSTEM

Check if the fuel pipe is connected firmly, and if the fuel tank is filled with fuel.

CAUTION:

Do not use pre-mixed fuel for this 4-stroke outboard engine.

2. CHECKING OIL LEVEL

- ① Check the engine oil level

Remove oil cap, check engine oil level..

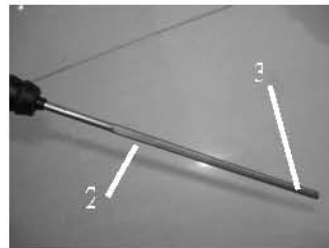
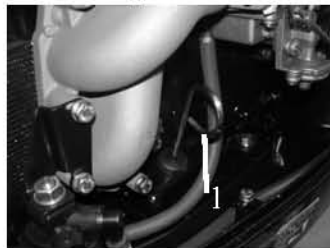

1. Oil cap 2. High position mark 3. Low position mark

Ensure the oil level between the marks of upper and lower. If above upper level, drain engine oil; if below lower mark, add engine oil up to upper level.

- ② Check the gear oil level

Remove the oil level plug. Check if the gear oil overflows at the oil level checking hole. If so, install the oil level plug and tighten it according to specified torque. Otherwise please add gear oil.



1. Oil level plug

3. CHECK STEERING SYSTEM

Check if steering is stable.

Check if steering friction is adjusted correctly.

Turn clamp handle screw clockwise to increase resistance.

Turn clamp handle screw counter clockwise to lower resistance.

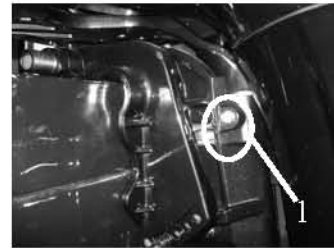

1. Clamp handle screw

4. CHECK SHIFT LEVER AND THROTTLE

Check if the shift lever is operated smoothly.

Check if the throttle grip is turned smoothly from full closed position to full open position.

5. CHECK ENGINE STOP SWITCH ASSY

Check if the engine stops when pushing the engine stop switch assembly or pulling out the stopper hang rope.

6. CHECK COOLING WATER CHECKING HOLE.

When the engine is running, check if cooling water overflows at the cooling water checking hole.



1. Cooling water checking hole

7. BREAKING-IN RUNNING

① Initial 1 hour: operate the engine at 2000 r/min or about a half throttle.

② The second hour: operate the engine at 3000 r/min or about 3/4 throttle.

③ The following 8 hours: operate the engine at full throttle continuously. Each operation time doesn't exceed 5 minutes.

8. INSPECTION AFTER BREAKING-IN RUNNING

① Check if gear oil contains water..

② Check if the fuel line leaks.

③ After breaking-in running, operate the engine at idling speed. Use cleaning tool to wash over the cooling water passage by fresh water.

9. AFTER BREAKING-IN RUNNING, INSPECT IDLING SPEED.

① Preheating engine for 5 minutes.

② Using the tachometer to measure idling speed RPM.

If out of specification, adjust it. Idling speed: 900~1000 r/min.

③ Turn the throttle stop screw clockwise or counter clockwise until the specified idling speed is attained.

④ After adjusting idling speed, picking up RPM several times to check the engine's stability.



SPECIAL TOOLS AND DETECTION DEVICE

When performing maintenance and repair, you need to use all kinds of special tools and detection device. The use of correct tools will improve the work efficiency and avoid of the damage to the people and outboard engines.

SPECIAL TOOLS:



Piston slider



Flywheel gripper and puller

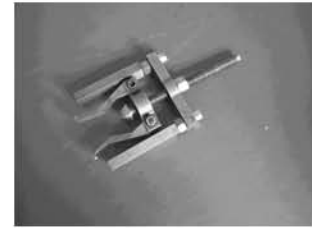

Bearing puller



Valve spring compressor



Housing oil seal installer



Lower casing cover bearing installer



Lower casing cover barrel bearing installer,



Lower casing cover oil seal installer

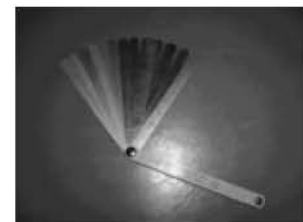

Space gage



Needle bearing installer



Oil cleaner spanner



Bearing block copper sleeve installer



Bearing block oil seal installer



Forward gear bearing installer

DETECTION DEVICE:

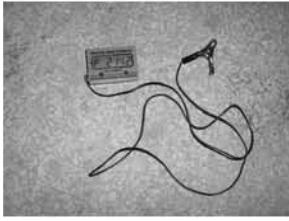

Digital tachometer



Digital circuit tester



Peak voltage adaptor

EXPLOSIVE DRAWING AND SYMBOL

EXPLOSIVE DRAWING

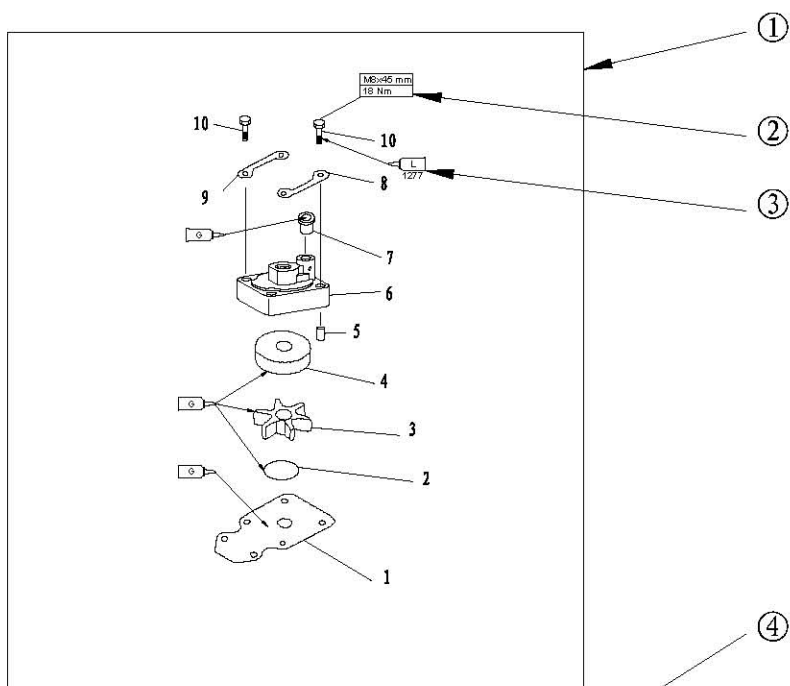

参照号码	零件编号	零件名称	数量	备注
REF.	PART NO.	DESCRIPTION	QTY	REMARKS
1	F15-06000007	外板板	1	OUTER PLATE
2	JASO F404-96	水泵壳密封圈O-45	1	O-RING
3	F15-06050000	水泵叶轮组件	1	IMPELLER
4	F15-06060002	水泵内壳	1	INNER SHELL, WATER PUMP
5	F15-00000013	定位销φ4X12	2	PIN, DOWEL
6	F15-06060001	水泵壳体	1	WATER PUMP HOUSING
7	F15-02000004	水管密封圈上	1	UPPER SEAL, WATER PIPE
8	F15-06060004	泵壳水管密封圈	1	SEAL
9	F15-06000014	泵壳固定板	2	FIXED PLATE, WATER PUMP
10	GB/T5783-2000	六角螺栓 M8X45	4	BOLT, HEXAGON

- ① Parts explosive drawing.
- ② Screw specification and specified torque.
- ③ Oil, fluid sealant or locking substance daubing point.
- ④ Spare parts details.

SYMBOL

Daub engine oil	Daub waterproof grease	Daub screw locking substance 1277	Daub screw locking substance 1243	Daub fluid sealant

SPECIFICATIONS

OUTBOARD ENGINE SPECIFICATIONS

Item		Description	Item	Description		
Dimension	Overall length	1001mm	Power Unit	Ignition system	C.D.I	
	Overall width	427mm		Starting enrichment	Choke valve	
	Overall height	S		1080mm	Spark plug	DPR7HS
		L		1207mm	Exhaust system	Under water
Weight	S	49kg		Lubrication system	Pressure lubrication	
	L	51kg	Fuel type	Unleaded regular gasoline		
Performance	Max output	7.3Kw(9.9hp)@5000r/min	Fuel and Oil	Fuel standard	PON86、RON91	
		9.9Kw(13.5hp)@5000r/min		Fuel tank capacity		
		11Kw(15hp) @5000r/min		Recommended engine oil	API SE, SF, SG, SH, SJ SAE 10W30, 10W40	
	Full throttle operation	4500~5500 r/min		Engine oil quantity	1.2L	
	Max fuel consumption	3.5L/h@5500 r/min(7.3Kw)		Recommended gear oil	Hypoid gear oil SAE # 90	
		5.3L/h@5500 r/min(11Kw)				
Idle speed (Neutral)	950±50 r/min	Gear oil quantity		250 cm ³		
Power Unit	Type	4 stroke, OHV		Bracket	Tilt angle	8°, 12°, 16°, 20°
	Number of cylinders	2	Tilt-up angle		63°	
	Displacement	323cm ³	Steering angle		45° +40°	
	Bore×Stroke	59mm×59mm	Drive Unit	Gear positions	F-N-R	
	Compression ratio	9.19:1		Gear ratio	2.08	
	Min. compression pressure	765kPa		Gear type	Spiral bevel gear	
	Number of carburetors	1		Clutch type	Dog clutch	
	Control system	Tiller control		Propeller drive system	Spline	
	Starting system	Recoil starter				

MAINTENANCE INFORMATION

Power unit

Item		Description	Item		Description	
Cylinder Head	Warp limit	0.1mm	Valve	Valve clearance (cold)	Intake	0.15~0.25mm
	Camshaft inside diameter	35.000~35.012mm			Exhaust	0.20~0.30mm
	Rocker shaft outside diameter	12.941~12.951mm		Face width	Intake	1.98~3.11mm
	Rocker inside diameter	13.000~13.018mm			Exhaust	1.98~3.11mm
Cylinder	Bore	59.00~59.015mm		Seat width	Intake	0.6~0.8mm
	Wear limit	59.1mm			Exhaust	0.6~0.8mm
	Taper limit	0.08mm		Margin thickness	Intake	0.50~0.90mm
	Out of round limit	0.05mm			Exhaust	0.50~0.90mm
Piston	Piston diameter	58.950~58.965mm		Head diameter	Intake	27.9~28.1mm
	Measuring point height	5mm (from the bottom of piston)			Exhaust	21.9~22.1mm
	Piston-to-cylinder clearance	0.035~0.065mm		Stem outside diameter	Intake	5.475~5.490mm
	Pin boss inside diameter	14.004~14.015mm			Exhaust	5.460~5.475mm
Piston pin outside diameter		13.996~14.000mm	Guide inside diameter	Intake	5.500~5.512mm	
Piston ring	Top ring	Thickness		1.17~1.19mm		Exhaust
		Breadth	2.0~2.20mm	Stem to guide clearance	0.025~0.052mm	
		End gap	0.15~0.30mm		Stem roundness limit	0.01mm
		Side clearance	0.04~0.08mm	Rocker shaft outside diameter		12.941~12.951mm
	2nd ring	Thickness	1.47~1.49mm	Rocker inside diameter		13.000~13.018mm
		Breadth	2.50~2.70mm	Valve spring	Free length	34.40mm
		End gap	0.30~0.50mm		Free length limit	32.68mm
		Side clearance	0.02~0.04mm		Tilt limit	1.5mm
	Thickness	2.31~2.51mm	Connecting rod		Small end inside diameter.	14.015~14.029mm
	Oil ring	Breadth		2.30~2.60mm	Big end inside diameter.	31.031~31.042 mm
End gap		0.20~0.70mm		Big end oil clearance	0.021~0.045mm	
Side clearance		0~0.22mm				

Camshaft	Height	Intake	27.596~27.696mm	Crankshaft	Journal diameter	34.997~35.009 mm
		Exhaust	27.616~27.716mm		Crankpin diameter	30.997~31.009 mm
	Round diameter	23.950~24.050mm	Crankpin width		21.00~21.07mm	
	Journal diameter	34.935~34.955mm	Big end side clearance		0.05~0.22mm	
	Camshaft round limit	0.03mm	Round limit		0.05mm	
Oil pump	Discharge	5.70L/min	Thermostat	Opening temperature	58~62°C	
	Safety valve opening pressure	388.0~450.0kPa		Full-opening temperature	70°C	
	Outside rotor to housing clearance	0.100~0.150mm		Valve lift height	3mm	
	Outside rotor to inside rotor clearance	0.040~0.140mm				
	Rotor to cover clearance	0.030~0.090mm				

Lower unit

Item		Description	Item		Description
Gear Clearance	Drive gear to forwarder gear	0.19~0.86mm	Gear Clearance	Forwarder gear shim	0.10, 0.12, 0.15, 0.18, 0.30, 0.40, 0.50mm
	Drive gear to back gear	0.95~1.65mm		Back gear shim	0.10, 0.20, 0.30, 0.40, 0.50mm
	Drive gear shim	1.13, 1.22mm			

Ignition system

Item		Description	Item		Description
Ignition timing		BTDC 30°	Pulsed coil resistance		234~348 Ω
Spark plug gap		0.8~0.9mm	Ignition assembly resistance	Primary coil	0.16~0.25 Ω
CDI output peak voltage	Start (load)	155V		Secondary coil	3.92~6.65K Ω
	1500r/min	170 V	Charge coil peak voltage	Start (no-load)	175V
	3500r/min	170 V		Start (load)	170V
Pulsed coil peak voltage	Start (no-load)	4.0 V		1500rpm	180V
	Start (load)	4.0 V	3500rpm	180V	
	1500r/min (load)	9 V	Charge coil resistance		272~408 Ω
	3500r/min (load)	17V			

Charge system

Item		Description	Item	Description	
Charge current	Min. (3000 r/min)	5.5 A	Light coil output	Start (load)	14 V
	Max. (5000 r/min)	6.0 A		1500r/min (no-load)	30 V
Rectifier peak voltage	3000r/min (no-load)	24 V		3500r/min (no-load)	70 V
	5000r/min (no-load)	38 V	Light coil resistance		0.33~0.72 Ω

TIGHTENING TORQUE

Specified torque

Part to be tightened		Part name	Thread size	Quantity	Torque	
Power unit	Safety valve		—	1	8Nm	
	Spark plug		—	M12	1	18 Nm
	Recoil starter		Bolt	M6	3	8 Nm
	Flywheel		Nut	M16	1	110 Nm
	Carburetor		Bolt	M6	2	10 Nm
	Intake manifold		Bolt	M6	4	8 Nm
	Cylinder head cover		Bolt	M6	4	8 Nm
	Cylinder head	1st tightening	Bolt	M8	4	15 Nm
		2nd tightening				30 Nm
		1st tightening	Bolt	M6	3	6 Nm
		2nd tightening				12 Nm
	Oil filter		—	—	1	18 Nm
	Oil filter stud		—	—	1	40 Nm
	Locknut (rocker arm)		Nut	M6x0.75	4	14 Nm
	Oil pump		Bolt	M6	2	8 Nm
	Power unit assembling		Bolt	M8	6	21 Nm
	Exhaust cover	1st tightening	Bolt	M6	7	6 Nm
		2nd tightening				12 Nm
	Breather cover		Bolt	M6	3	8 Nm
	Crankcase	1st tightening	Bolt	M8	4	15 Nm
		2nd tightening				30 Nm
		1st tightening	Bolt	M6	6	6 Nm
		2nd tightening				12 Nm
	Connecting rod	1st tightening	Bolt	M7	2	10 Nm
		2nd tightening				21Nm
	Oil pressure switch		—	—	1	18 Nm
	Driven belt pulley		Bolt	M6	1	13 Nm
	Timing pulley		Nut	M28	1	54 Nm

Lower unit	Lower unit mounting	Bolt	M8	4	18 Nm
	Lower unit housing cover	Bolt	M6	2	8Nm
	Anode	Bolt	M6	1	8 Nm
	Water pump housing	Bolt	M8	4	18 Nm
	Water pump base	Bolt	M8	2	18 Nm
	Water inlet	Bolt	M5	2	5 Nm
	Oil drain bolt	Bolt	M8	1	9 Nm
	Oil filler hole	Bolt	M8	2	9 Nm
	Pinion	Nut	M8	1	25 Nm
	Propeller nut	Nut	M10	1	17 Nm
Upper Unit	Steering handle mounting	Bolt	M8	1	18 Nm
	Shift lever bracket	Bolt	M6	1	4.5 Nm
	Clamp bracket	Nut	M8	1	13 Nm
	Oil drain bolt	Bolt	M14	1	27 Nm
	Ignition assy	Bolt	M6	2	8 Nm

General torque

Nut (a)	Bolt (b)	Torque
8mm	M5	5Nm
10mm	M6	8 Nm
12mm	M8	18 Nm
14mm	M10	36 Nm
17mm	M12	43 Nm

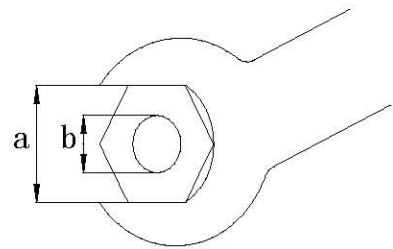

PERIODIC SERVICE MAINTENANCE TIME TABLE

Items	Contents	Initial maintenace		General maintenance period	
		10 hours (month)	50 hours (3 months)	100 hours (6 months)	200 hours (1 year)
Anode	Inspection/ replacement		○	○	
Spark plug	Cleaning/ adjustment / replacement	○		○	
Grease points	Greasing			○	
Bolts and nuts	Inspection	○		○	
Fuel filter	Inspection/ replacement	○	○	○	
Fuel tank	Inspection/ cleaning				○
Throttle cable	Inspection/ adjustment/ replacement	○			○
Idling speed	Inspection/ adjustment	○		○	
Start-in-gear projection	Inspection/ adjustment	○		○	
Engine oil	Replacement	○		○	
Oil filter	Replacement				○
Valve clearance (OHC)	Inspection/ adjustment	○		○	
Ignition timing	Inspection	○		○	
Thermostat	Inspection				○
Cooling water passage	Inspection/ Cleaning		○	○	
Gear oil	Replacement	○		○	
Water pump	Inspection				○
Propeller	Inspection/ replacement		○	○	
Timing belt	Inspection/ replacement	○		○	

CAUTION:

After running the outboard engine in salt water, waste water or mud water, wash over the engine by fresh water immediately.

If using leaded gasoline frequently, check the valve and components each 100 hours.

Timing belt should be changed every 1000 hours (5 years).

FUEL SYSTEM

1. CHECK FUEL TANK, CARBURETOR, FUEL PUMP AND FUEL PIPE
Check if fuel tank, carburetor, fuel pump and fuel pipe are damaged or leaked.
Replace if necessary.
Check if the fuel filter on the tank is dirty. Clean dirt or replace if necessary.

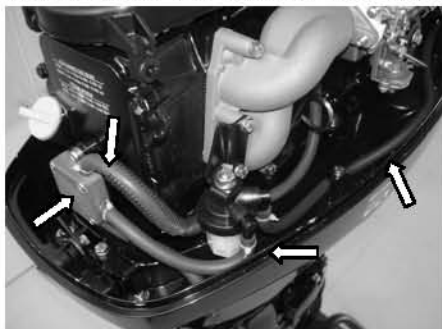

2. CHECK FUEL COCK AND FUEL JOINT
Check if fuel cock and fuel joint are cracked, damaged or leaking.
Replace if necessary.
3. CHECK FUEL FILTER
Check if fuel filter is cracked, damaged or has dirt inside.
If so, replace.



CAUTION:
Clean the spilled fuel.

POWER UNIT

Engine oil level

1. Remove oil rule, check engine oil level, if between the following marks of the upper and lower.

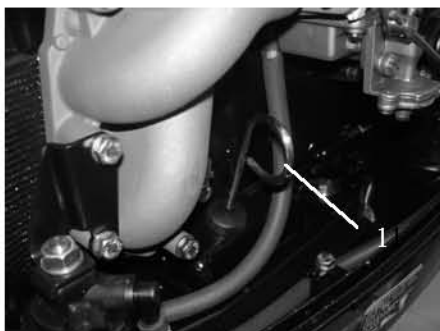

1. Oil rule

2. High position mark

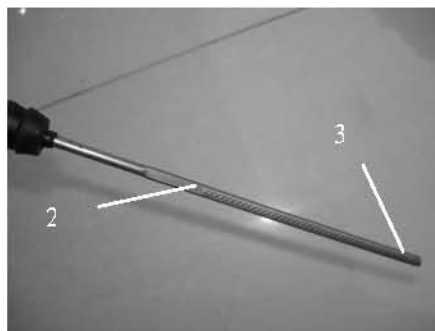

3. Low position mark

2. If above the upper mark, drain the engine oil; if below lower mark, add engine oil up to upper mark.

CAUTION:

Run the engine and then turn it off, wait for several minutes, and check the engine oil level by the oil rule again.

If the engine oil still not within the proper level, add/drain as needed.

Changing engine oil

1. Remove oil level plug, drain plug with washer and gasket; drain off the engine oil.

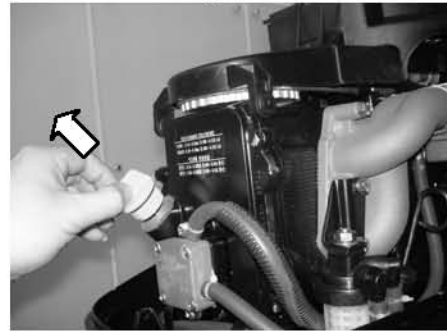

2. Install new bolt and washer; install drain plug.
3. Fill engine oil through oil filler hole.
Engine oil quantity: 1.0 L (Before changing oil filter)
1.2 L (After changing oil filter)
Oil type: API SE, SF, SE-SF, SG-CD SAE 10W30, 10W40
4. Install oil level plug.
5. Check engine oil level.

Valve clearance

1. Remove stopper hang rope from engine stop switch assy.
Remove spark plug cap from spark plug.
2. Remove starter and belt cover.
3. Remove fuel pump and cylinder cover.
4. Rotate the flywheel clockwise to make the mark “1” on driven pulley align with the mark “▼” on the cylinder head.
Check the clearance between the intake and exhaust valves of the upper cylinder. Adjust it if necessary.
5. Rotate the flywheel clockwise to make the mark “2” on driven pulley align with the mark “▼” on the cylinder head.
Check the clearance between the intake and exhaust valves under the lower cylinder. Adjust it if necessary.

CAUTION:

Don't rotate the flywheel counter clockwise in case the valve system is damaged.

NOTE:

Adjust the valve clearance when the engine is cold.

Valve clearance (cold position)	Intake valve	0.15~0.25mm
	Exhaust valve	0.20~0.30mm

6. Loose lock nut, rotate adjusting bolt to reach the specified valve clearance.

NOTE:

Rotate adjusting bolt clockwise to reduce the valve clearance.

Rotate adjusting bolt counter clockwise to increase the valve clearance.

7. Re-assemble the spare parts.

Spark plug

1. Remove spark plug cap and spark plug.
2. Clean off carbon build-up on the electrodes.
3. Check if the electrodes are corroded or have deposit, or if the washer is damaged. If necessary, change the spark plug.
Spark plug type: DPR7HS
4. Inspect if the spark plug gap is within specification. If necessary, change the spark plug.

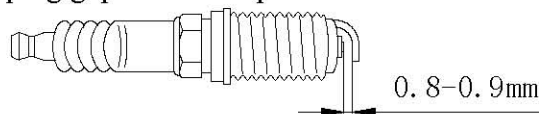

5. Install spark plug. Use spark plug spanner to tighten it according to specified torque.
Specified torque: 18 Nm

CONTROL SYSTEM

Throttle grip

Recoil start type

1. Turn the throttle grip to fully closed position.
2. Check if the throttle cable is slack, if the throttle lever touches the throttle stop screw, or if the arresting stop on the throttle accelerograph enforce touches the check plate on the fixed mount.
3. Loosen the throttle cable adjusting screw, adjust the throttle cable position, and tighten throttle cable adjusting screw.

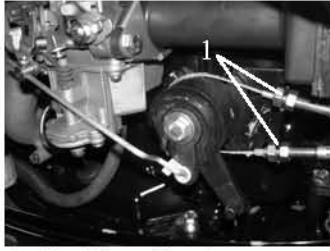

1. throttle cable stop screw

Electric start type

1. Turn the gear shift lever to neutral position.
2. Check if the arresting stop on the throttle accelerator enforce touches the check plate on the bracket.

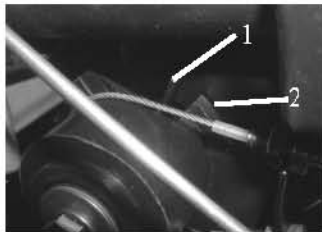

1. check plate 2. arresting stop

3. Loosen the lock nut and take out the cotter pin, then remove the cable joint.

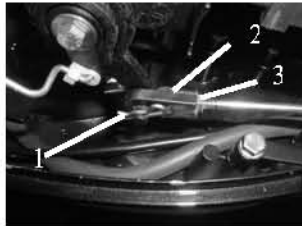

1. cotter pin 2. cable joint 3. lock nut

4. Adjust the joint position to make the joint hole align with the pin on the throttle accelerator enforce.

CAUTION:

The cable joint must be screwed in for over 8mm.

5. Fit on the cotter pin and tighten the lock nut.

Idling speed

Check idling speed, and adjust it if necessary.

1. Preheat engine for 5 minutes.
2. Attach the tachometer to the spark plug wire to measure idling speed RPM. If out of specification, adjust it.
Idling speed: 900~1000 r/min

- Turn the throttle stop screw clockwise or counter clockwise, until the specified idling speed is attained.

NOTE:

Turn clockwise to increase idling speed.

Turn counter clockwise to decrease idling speed.

If necessary, turn the idling speed screw on the carburetor clockwise or counter clockwise, until the specified idling speed is attained.

CAUTION:

Before adjusting the idling speed, the throttle cable should be properly adjusted.

After adjusting the idling speed, if necessary, you can adjust the throttle cable again.

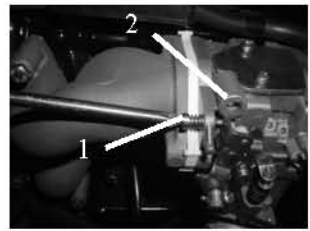

1. throttle stop screw
2. idling speed screw

Start-in-gear protection

Set the shift lever in neutral, and check if the tightwire end of the arrester aligns with the marking of the starter. If necessary, adjust the adjusting nut on the tightwire of the arrester, to make the tightwire end align with the marking.

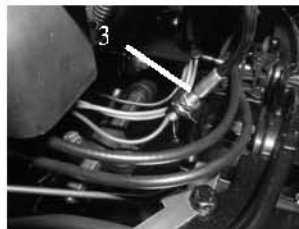
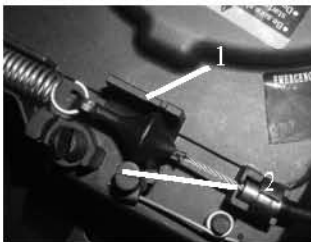

1. "■" marking 2. tightwire assy, arrester 3. adjusting nut

LOWER UNIT

Gear oil

Check gear oil level:

Remove the oil level plug screw. If the gear oil overflows, the oil level is correct; otherwise, add gear oil.



1. Oil level plug screw

Changing gear oil

- Hold the outboard engine in an upright position.
- Place a container with enough capacity under the outboard engine.

3) Remove the drain plug screw, the oil level plug screw, and then drain the gear oil.

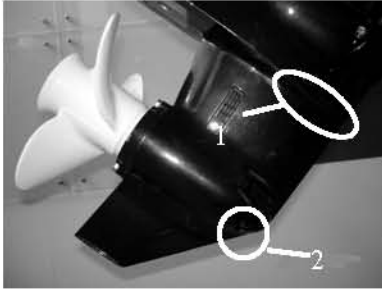

1. Oil level plug screw 2. Drain plug screw

4) Add gear oil through the drain plug hole using pressure filling device.

5) When gear oil overflows through the oil level plug hole, install the oil level plug screw.

6) Install the drain plug screw, then clean overflowing gear oil.

NOTE:

Check the drained gear oil. If the gear oil is milky, check the oil seal. Replace the oil seal if necessary. If the gear oil contains metal chippings, check the gear and bearing.

CAUTION:

Must change drain plug washer each time.

Lower unit leakage check

Connecting the leakage tester to the oil level plug hole to check for the lower unit leakage. If the pressure drops (pressure: 1 kg/cm^2), inspect the oil seal and components.

GENERAL INSPECTION

Anode

Inspect lower unit anode and engine anode (on the thermostat cover). Clean the greasy dirt and scales. If wear or damage is above 1/2, replace the anode.

CAUTION:

Cannot grease or paint the anode, or it will not operate properly.

Grease points

1. Refer the illustration for greasing points, paint the water resistant grease.

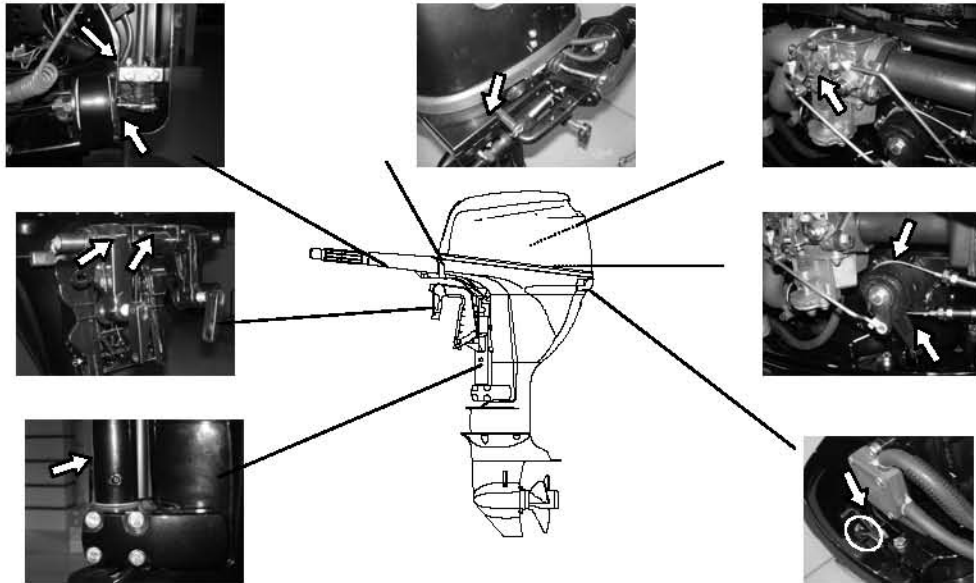

2. Paint anti-corrosion grease on the propeller shaft.



Cooling water passage

1. Inspect cooling water passage, if blocked, clean it.



1. Cooling water passage inlet

2. Place the outboard engine in the water and ensure the water level is above the anti-vortex plate, then start the engine.
3. Check if water overflows at the cooling water checking hole. If there is no flow or intermittent flow, check the cooling water passage.



1. Cooling water inlet



2. Cooling water checking hole

Thermostat

1. Remove the thermostat cover and thermostat.
2. Hang the thermostat in a container with water.
3. Heat the container.
4. Check the valve open height under the specified water temperatures. If out of order, change it.

Water temperature	Valve open height
Under 62°C	0.1mm
Over 70°C	Over 3mm

5. Fit on the thermostat and thermostat cover, then tighten the screws to specification.

RECOIL STARTER

NOTICE

When you service, always wear safety glasses and gloves. To prevent accidental start of the engine, remove the spark plug cap and remove stopper hang rope from stop switch assembly.

EXPLOSIVE DRAWING

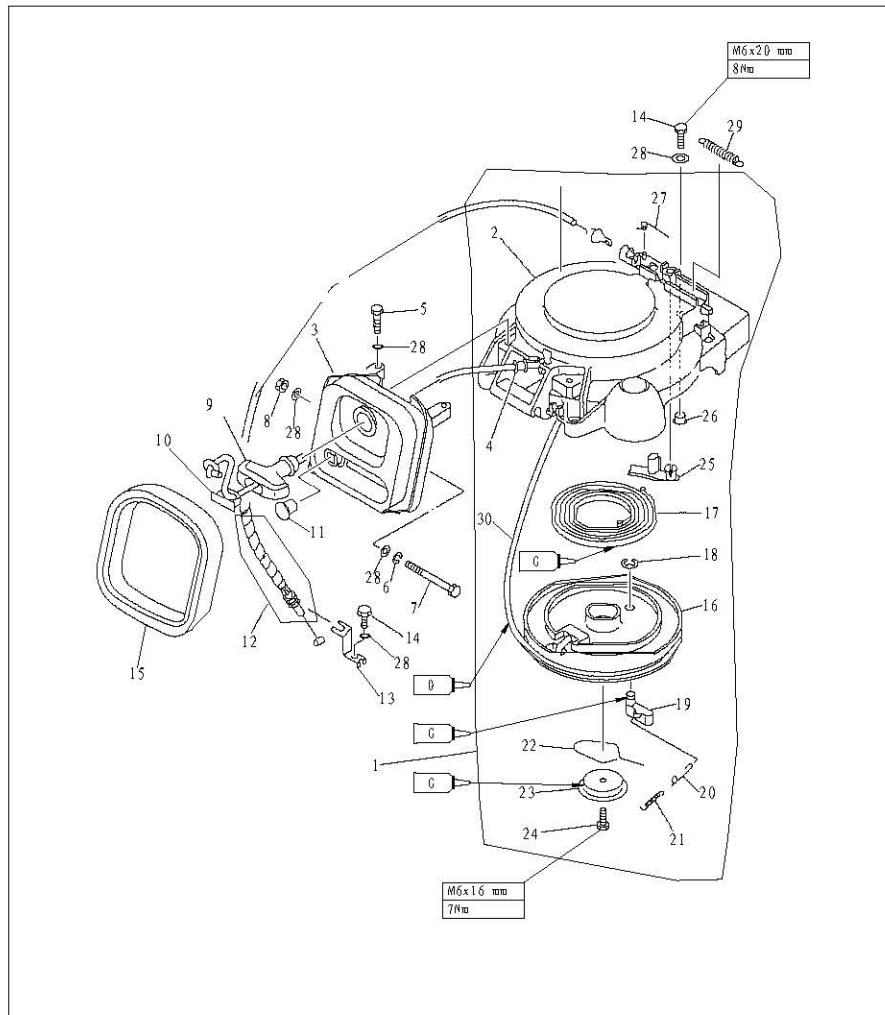

参照号码 SN.	零件编号 PART NO.	零件名称 DESCRIPTION	数量 QTY	备注 REMARKS
1	F15-07130000	起动手柄组件 STARTER ASSY	1	
2	F15-07130101	起动手柄外壳 CASE, STARTER	1	
3	F15-07130300	起动手柄架组合 FRAME, STARTER	1	
4	F4-04130013	起动手柄绳导向管 COLLAR	1	
5	GB/T5783-M6x25	六角螺栓M6x25 BOLT M6x25	2	
6	GB/T93-6	弹簧垫圈6 WASHER, SPRING	1	
7	GB/T5782-M6x90	六角螺栓M6x90 BOLT M6x90	1	
8	GB/T6170-M6	六角螺母M6 NUT M6	1	
9	F4-04130101	起动手柄 HANDLE, STARTER	1	
10	F4-04130102	起动手柄盖 COVER	1	

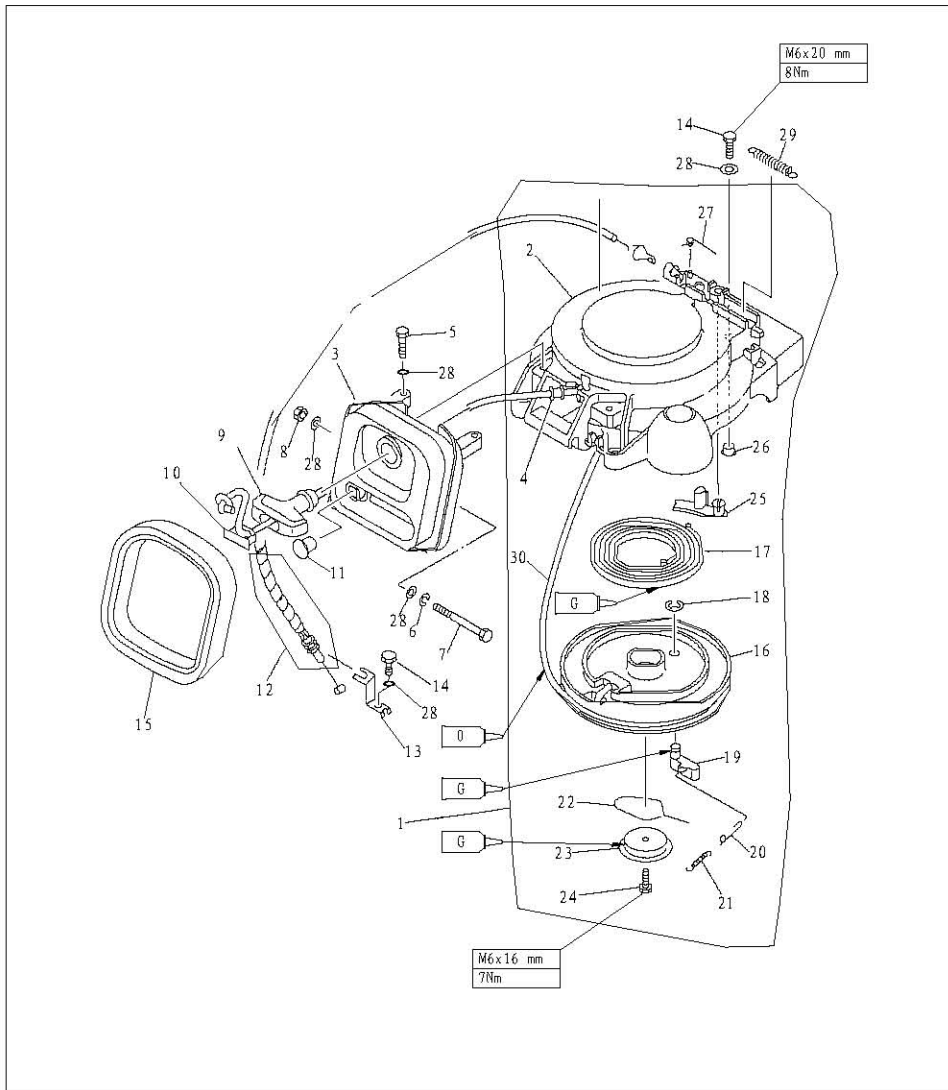

参照号码 SN.	零件编号 PART NO.	零件名称 DESCRIPTION	数量 QTY	备注 REMARKS
11	F15-07130305	橡胶堵头 GROMMET	1	
12	F15-05000028	制动器钢索组件 ARRESTER TIGHTWIRE ASSY	1	
13	F15-05000027	制动器钢索固定架 FRAME, ARRESTER TIGHTWIRE	1	
14	GB/T5783-M6x20	六角螺栓M6x20 BOLT M6x20	3	
15	F15-07130304	发泡密封圈 SEAL, FROTHY RUBBER	1	
16	F15-07130201	起动轮 WHEEL, START-UP	1	
17	F15-07130107	涡形弹簧 SPRING, VOLUTE	1	
18	GB/T896-8	开口档圈8 CIRCLIP 8	1	
19	F15-07130202	起动卡瓣 PAWL, DRIVE	1	
20	F15-07130204	卡瓣钢丝连杆 LINK, PAWL	1	

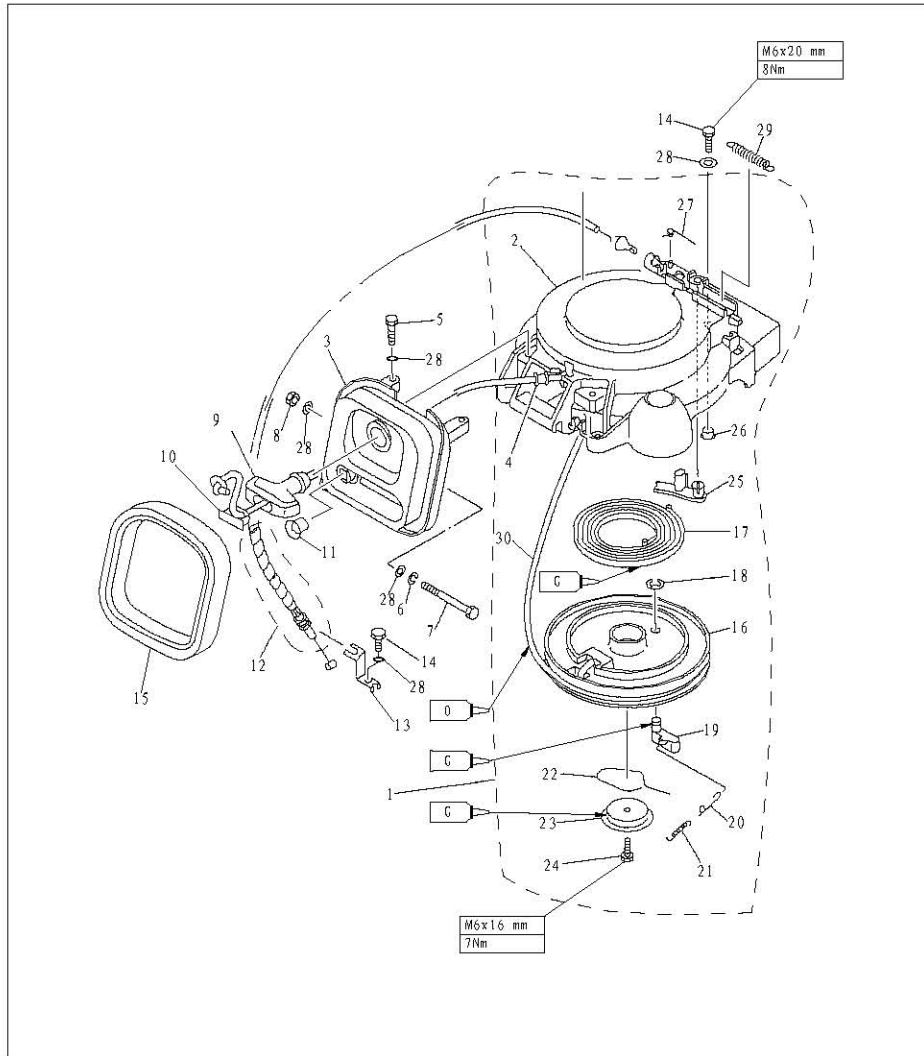

参照号码	零件编号	零件名称	数量	备注
SN.	PART NO.	DESCRIPTION	QTY	REMARKS
21	F15-07130203	卡瓣拉簧	1	SPRING, TENSION
22	F15-07130002	起动压板夹簧	1	SPRING, DRIVE PLATE
23	F15-07130001	起动压板	1	PLATE, DRIVE
24	GB/T5783-M6x16	六角螺栓M6x16	1	BOLT M6x16
25	F15-07130105	制动器	1	ARRESTER
26	F15-07130102	带肩衬套	3	BUSH, SHOULDER
27	F15-07130106	制动器扭簧	1	SPRING, ARRESTER
28	GB/T97.1-6	平垫圈6	8	WASHER PLATE
29	F15-05000029	制动器钢索拉簧	1	TIGHTWIRE, SPRING
30	F15-07130205	起动绳 (φ4x1.78米)	1	START LING

Electric start type

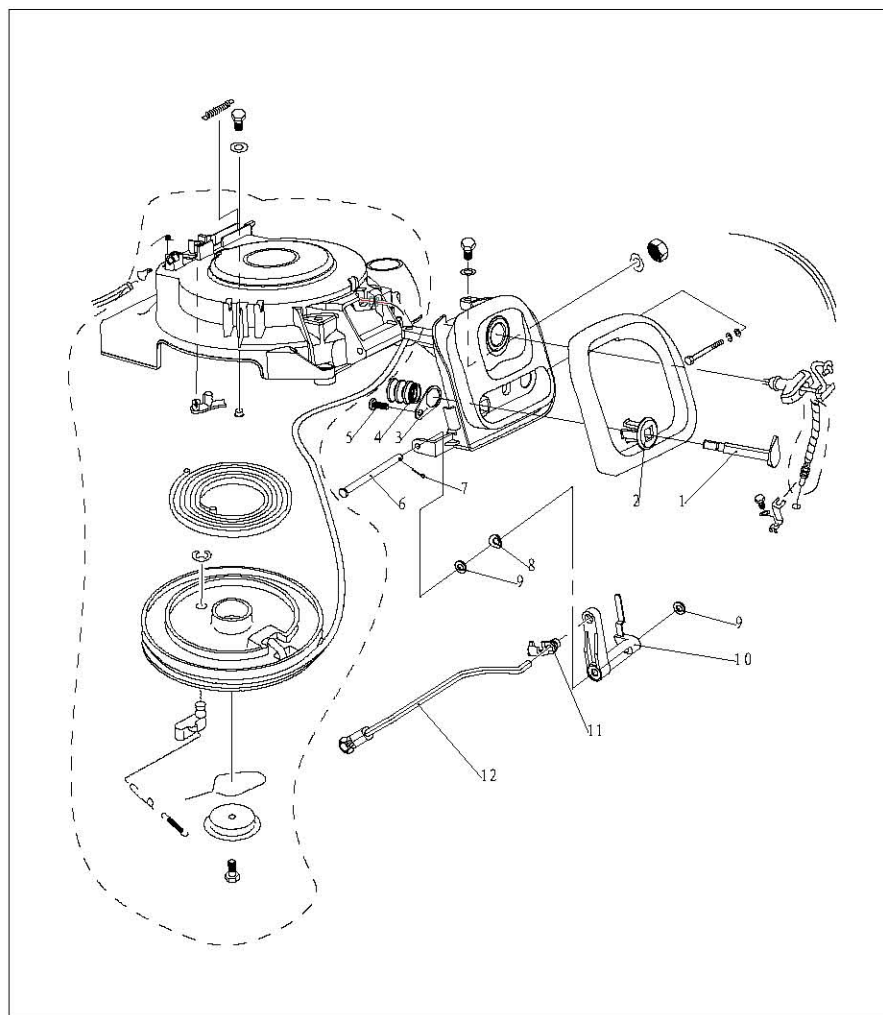

参照号码 SN.	零件编号 PART NO.	零件名称 DESCRIPTION	数量 QTY	备注 REMARKS
1	F15-07130306W	阻风门手柄B HANDLE "B"	1	
2	F15-05010001	阻风门导向套 BUSH	1	
3	F15-07130308W	护套定位板 PLATE	1	
4	F15-07130307W	波纹护套B BUSH , WAVE	1	
5	GB/T845-85	十字槽盘头自攻螺钉ST4.8×9 SCREW , PAN HEAD ST4.8x9	1	
6	F15-07130310W	摇臂销轴 SHAFT , ROCKER	1	
7	GB/T91-1.6×12	开口销1.6×12 COTTER PIN 1.6x12	1	
8	F15-07130312W	鞍形弹性垫圈5 WASHER , SPRING SADDLE	1	
9	F15-07130311W	尼龙垫圈5 WASHER , NYLON	2	
10	F15-07130309W	阻风门摇臂 ROCKER	1	
11	F15-07130314W	阻风门接头 TIE-IN	1	
12	F15-07130313	阻风门连杆组件 LINK ROD ASS'Y	1	

DISASSEMBLING

1. Open the top cowling.
2. Screw loosely the adjusting nut of the arrester tightwire.

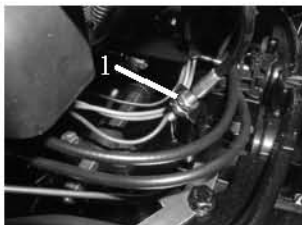

1. Adjusting nut

3. Remove the tightwire from the arrester.
4. Remove the starter fixing bolts, and remove the starter.



STARTER ROPE REPLACEMENT

1. Pull the starter rope out, and insert it in the notch of the start-up wheel. Turn the start-up clockwise until the volute spring is free.

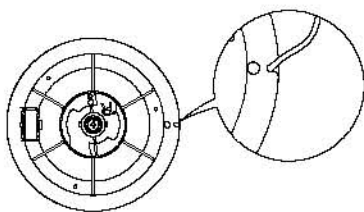

2. Pull the starter rope out completely.
3. Remove the starter handle cover from the starter handle, and remove the starter rope. Untie the knot at the end of the starter rope.
4. Pull out the starter rope from the start-up wheel completely.
5. Insert the new starter rope into the starter, and fix the starter rope onto the start-up wheel and starter handle. At the end of the rope tie a knot as shown.

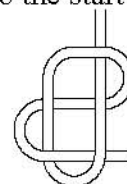

6. Insert the start rope in the notch of the start-up wheel and turn the start-up wheel several rounds in counter clockwise direction.
7. Pull the starter handle many times to check if the start-up wheel rotates stably. If necessary, repeat step 6 and step 7.

DISASSEMBLING AND INSPECTION

Recoil start type

1. Remove the start rope and start frame assy.
2. Remove drive plate screw, and remove the drive plate and drive plate spring.
3. Remove the start-up wheel.

WARNING:

Uninstall the start-up wheel carefully, to ensure that the volute spring does not pop out to hurt people.

4. Remove the volute spring.
5. Remove the arrester and arrester spring.
6. Inspect if the arrester is cracked, worn or damaged. Replace if necessary.

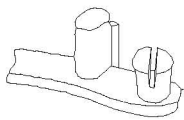

7. Inspect if the drive pawl is cracked, worn or damaged. Replace if necessary.

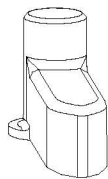

8. Check if the tension spring and pawl link are cracked, cranked or damaged. Replace if necessary.

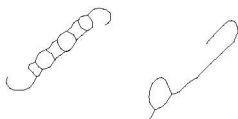

9. Check if the volute spring is broken, cranked or damaged. Replace if necessary.

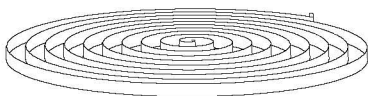

Electric start type

1. Remove the link rod assy of chock valve.
2. Remove the cotter pin and rocker shaft.
3. Remove the rocker.
4. Remove the bush plate, guide bush and chock valve handle.
5. Check if the link rod assy is cranked or deformed. Replace if necessary.
6. Check if the chock valve rocker and handle are cracked or damaged. Replace if necessary.

ASSEMBLING

Reverse the steps of disassembling starter.

INSTALLATION

1. Put starter onto the power unit.
2. Screw the hexagon bolt, and tighten it according to the specified torque.
3. Install the arrester tightwire.
4. Adjust the adjusting nut on the tightwire of the arrester, and align the arrester tightwire end with the marking of the starter case.

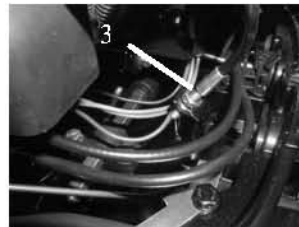
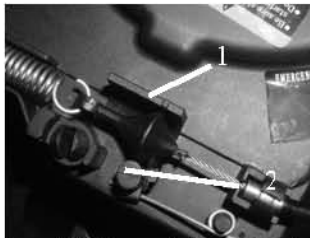

1. “■” marking 2. Arrester tightwire 3. Adjusting nut

IGNITION SYSTEM

NOTICE

When checking and repairing the ignition system, keep your hand, clothes, hair or personal belongings away from the rotating flywheel.

Check ignition coil on insulated working table, to prevent electricity leak and electroshock.

Don't touch the ignition coil or spark plug when the engine is running, to avoid electroshock. Keep the wires away from the rotating flywheel, to prevent the wire from being cut, or the insulating layer of the wire from being worn.

When replacing fixing parts such as nuts and bolts, only parts from original manufacturer or parts made of same material and with strength can be used. Parts must be tightened according to the specified torques.

EXPLOSIVE DRAWING

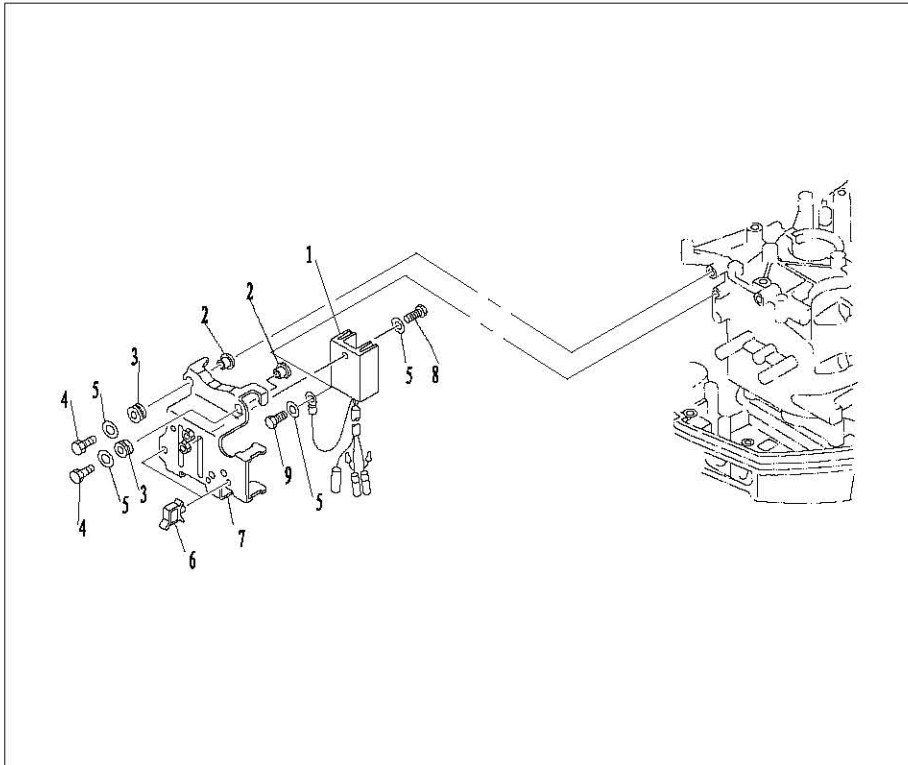

参照号码 SN.	零件编号 PART NO.	零件名称 DESCRIPTION	数量 QTY	备注 REMARKS
1	F15-07060001	整流器组件 RECTIFIER & REGULATOR ASSY	1	
2	F15-07060004	衬管 LINER	4	
3	F15-07060003	减震圈 GASKET, SHOCK ABSORPTION	4	
4	GB/T5783-M6x25	六角螺栓M6 x 25 HEXAGON BOLT M6 x 25	4	
5	GB/T97.1-6	平垫圈6 WASHER	6	
6	F15-07060005	方形线卡B QUADRATE CLAMP	2	
7	F15-07060002	整流器支座 BRACKET, RECTIFIER	1	
8	GB/T5783-M6x16	六角螺栓M6 x 16 HEXAGON BOLT M6 x 16	1	
9	GB/T5783-M6x12	六角螺栓M6 x 12 HEXAGON BOLT M6 x 12	1	

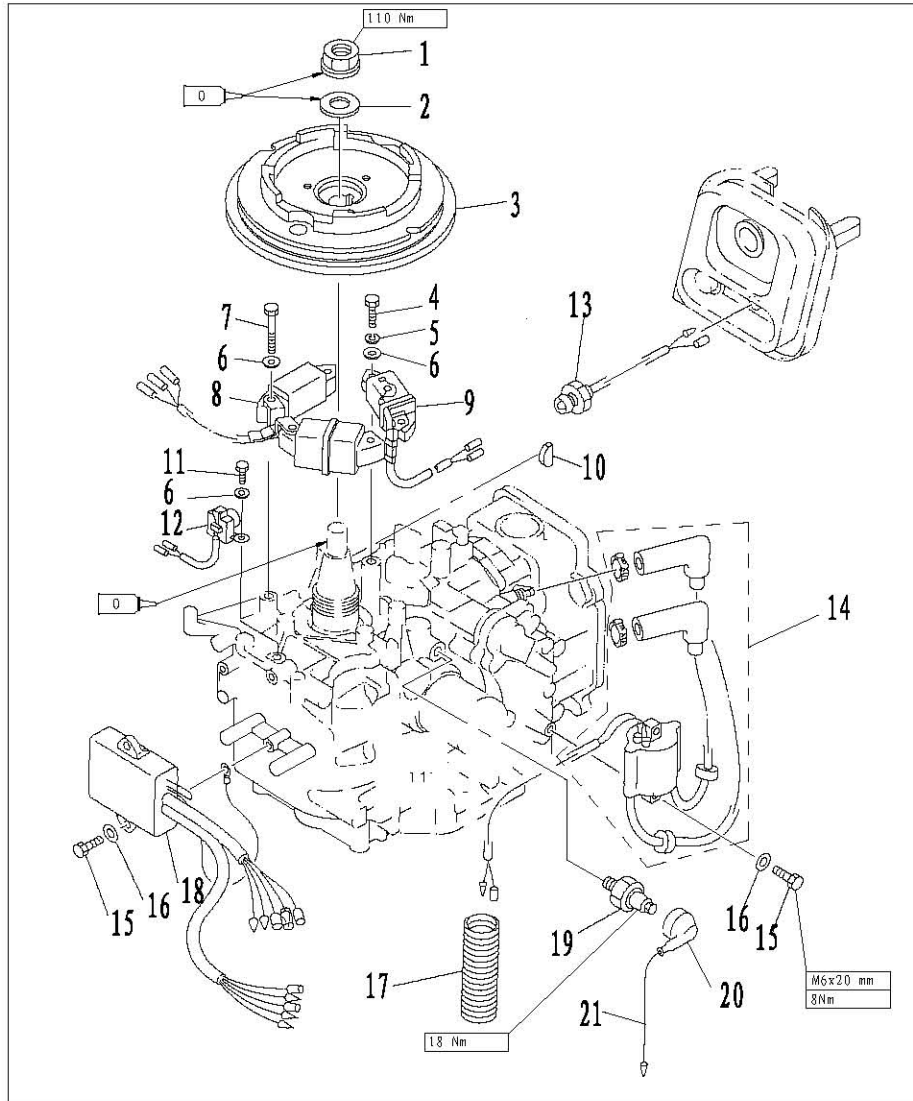

参照号码 SN.	零件编号 PART NO.	零件名称 DESCRIPTION	数量 QTY	备注 REMARKS
1	F15-07000006	飞轮螺母 NUT, FLYWHEEL	1	
2	F15-07000005	飞轮螺母垫圈 WASHER, FLYWHEEL NUT	1	
3	F15-07070000	飞轮组件 FLYWHEEL ASSY	1	
4	GB/T5783-M6x25	六角头螺栓M6 x 25 HEXAGON BOLT M6 x 25	2	
5	GB93-6	弹簧垫圈6 WASHER, SPRING	2	
6	GB/T97.1-6	平垫圈6 WASHER	8	
7	GB/T5783-M6x30	六角头螺栓M6 x 30 HEXAGON BOLT M6 x 30	4	
8	F15-07000400	充电线圈A、B组合 COIL, CHARGE "A" & "B" ASSY	1	
9	F4-07000300	磁电机线圈组合 COIL	1	
10	F15-07000004	飞轮半圆键 KEY, SEMICIRCLE FLYWHEEL	1	
11	GB/T5783-M6x16	六角头螺栓M6 x 16 HEXAGON BOLT M6 x 16	2	
12	F15-07000200	触发线圈组件 COIL, PULSER	1	

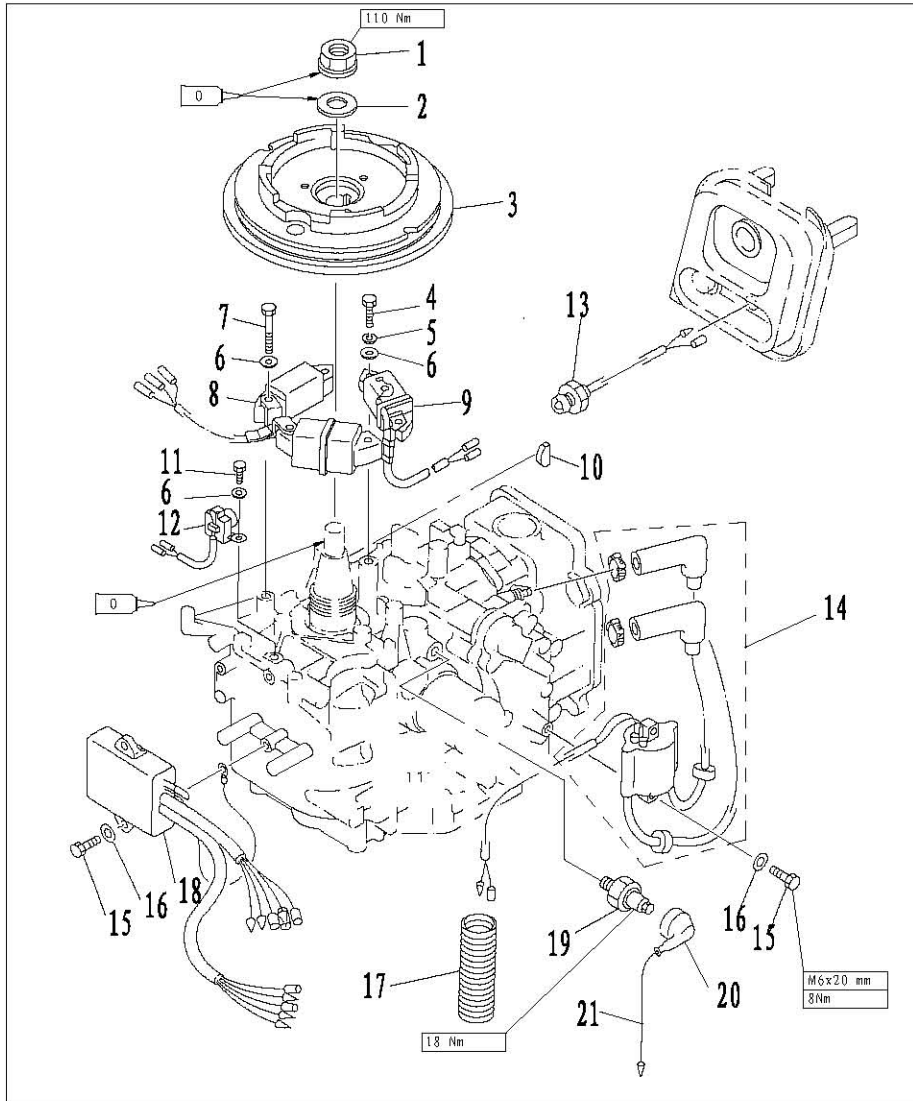

参照号码 SN.	零件编号 PART NO.	零件名称 DESCRIPTION	数量 QTY	备注 REMARKS
13	F15-07130303	机油指示灯组件 EMERGENCY SIGNAL LIGHT ASSY	1	
14	F15-07000600	高压包组件 HIGH PRESSURE ASSY	1	
15	GB/T5783-M6x20	六角头螺栓M6×20 HEXAGON BOLT M6×20	4	
16	GB/T97.1-6	平垫圈6 WASHER	4	
17	F15-07000003	波纹管 φ27×φ22.5×71 RIPPLE TUBE	1	
18	F15-07000500	点火控制模块 C. D. I. UNIT ASSY	1	
19	F15-07010103	机油压力传感器 OIL PRESSURE SENSOR	1	
20	F15-07010101	绝缘护套 JACKET, INSULATION	1	
21	F15-07010102	导线组件 LEAD WIRE ASSY	1	

Electric start type

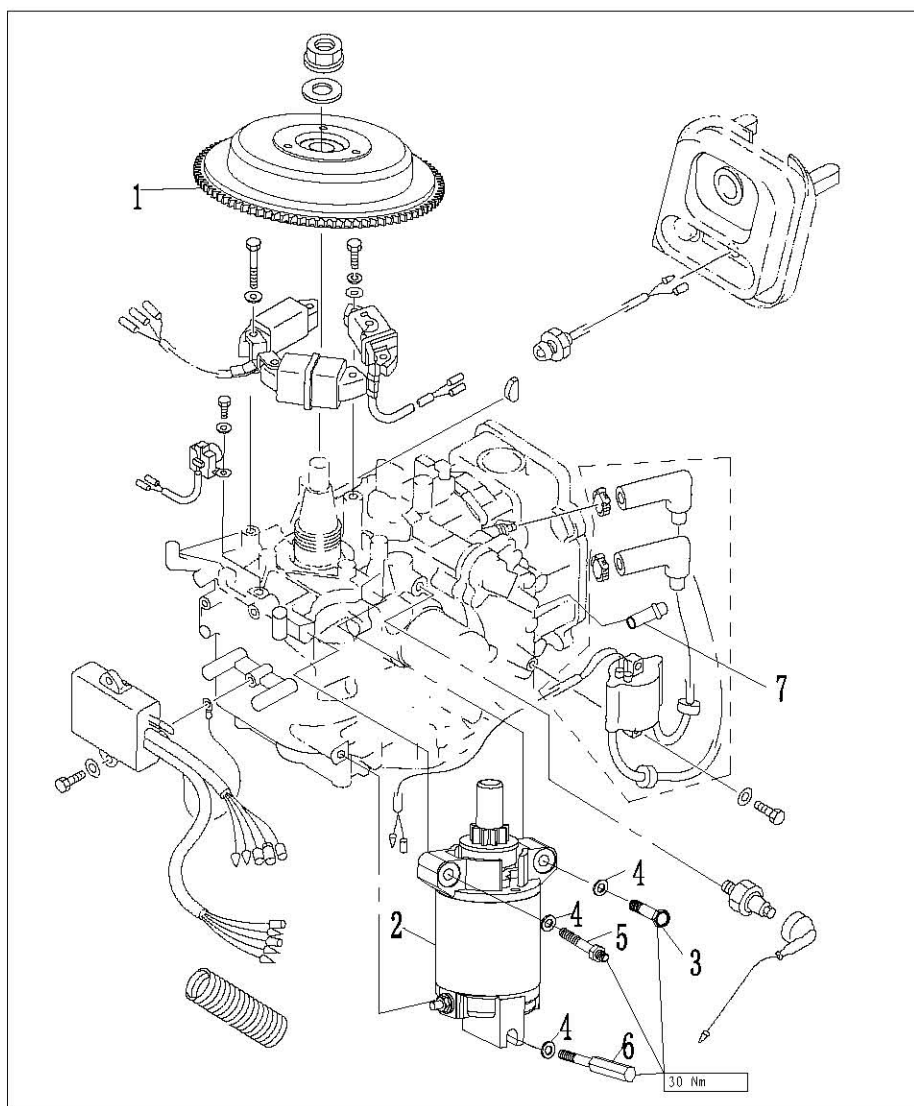

参照号码 SN.	零件编号 PART NO.	零件名称 DESCRIPTION	数量 QTY	备注 REMARKS
1	F15-07070100W	飞轮组件 FLYWHEEL ASSY	1	
2	F15-07150100W	启动电机 STARTUP MOTOR	1	
3	GB/T5782-M8x50	六角头螺栓M8x50 HEXAGON BOLT M8x50	1	
4	GB/T97.1-8	平垫圈8 WASHER 8	3	
5	F25-05170001W	电机固定螺栓M8 FIXATION BOLT, MOTOR	1	
6	F15-07150002W	柱状螺栓M8 COLUMNAR BOLT	1	
7	F25-05010402W	出水嘴 WATER GAP	1	

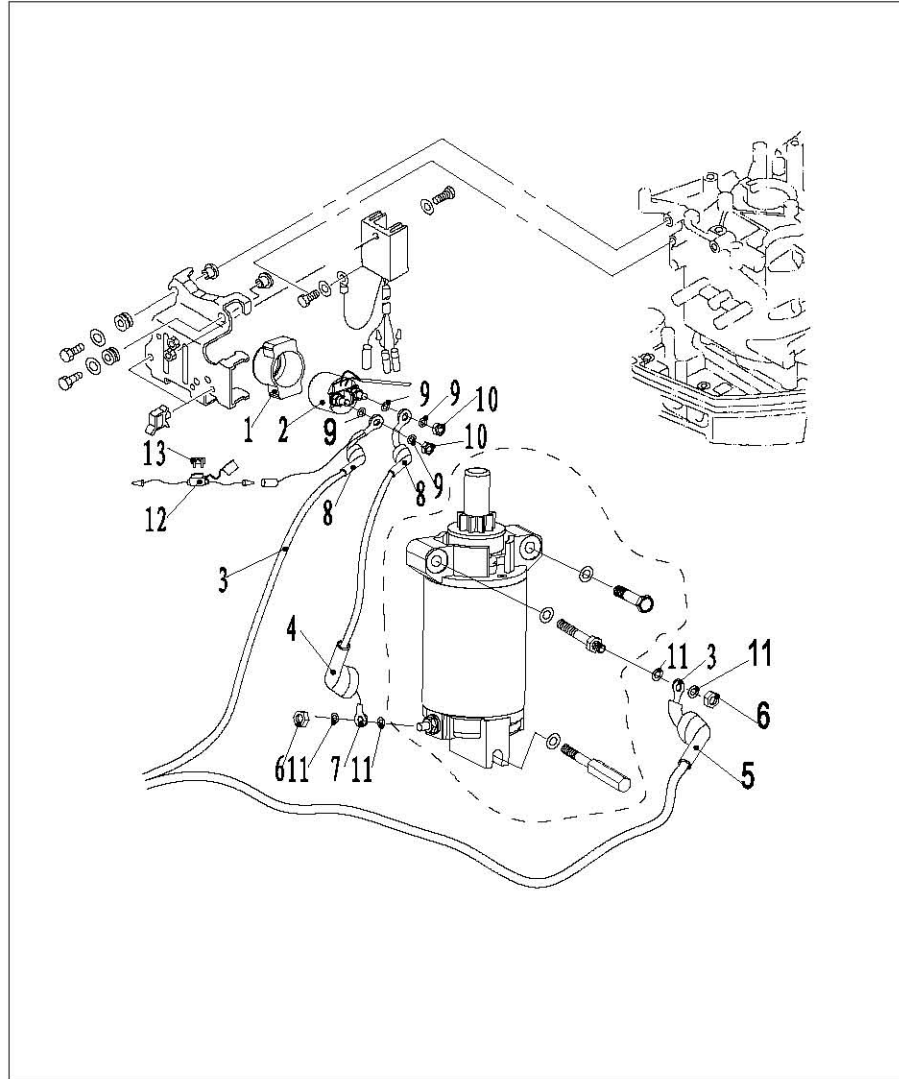

参照号码 SN.	零件编号 PART NO.	零件名称 DESCRIPTION	数量 QTY	备注 REMARKS
1	F15-07150301W	继电器护套 RELAY JACKET	1	
2	F15-07150300W	继电器 RELAY	1	
3	F15-07150200W	电源连接线 LINE, POWER SOURCE	1	
4	F25-05170201W	电源连接线护套A COVERING A, POWER SOURCE LINE	1	
5	F25-05170202W	电源连接线护套B COVERING B, POWER SOURCE LINE	1	
6	GB/T6170-M8	六角螺母M8 HEXANGULAR NUT M8	2	
7	F15-07150500W	电机连接线 CONNECTION LINE, MOTOR	1	
8	F15-07150501W	电机连接线护套 JACKET, CONNECTION LINE	2	
9	GB/T97.1-6	平垫圈 6 WASHER 6	4	
10	GB/T6170-M6	六角螺母M6 HEXANGULAR NUT M6	2	HSn62-1
11	GB/T97.1-8	平垫圈 8 WASHER 8	4	
12	F25-05090100W	熔断器组件 (JER-709J) FUSE ASSY	1	
13	F15-07150001W	保险丝20A FUSE	1	

WIRING DIAGRAM

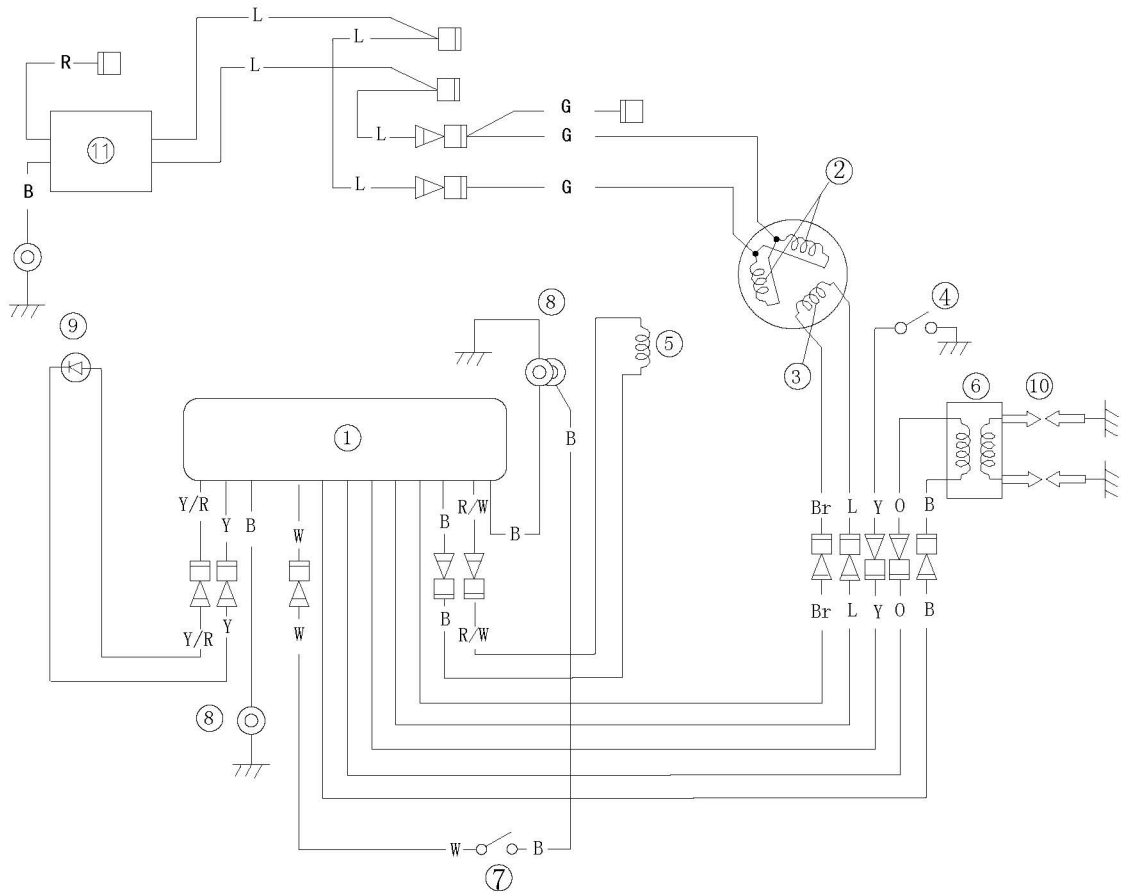

- | | | | |
|-----------------|--------------------|----------------------|--------------|
| ① C D I | ④ Oil press switch | ⑦ Engine stop switch | ⑩ Spark plug |
| ② Lighting coil | ⑤ Pulsed coil | ⑧ Grounding wire | |
| ③ Charge coil | ⑥ Ignition coil | ⑨ Oil alert light | |

Wire beam color:

W	White	O	Orange	Y/R	Yellow/Red
B	Black	L	Blue	R/W	Red/White
R	Red	G	Green		
Y	Yellow	Br	Brown		

SPARK PLUG IGNITION

1. Remove spark plug cap from spark plug.
2. Connect the ignition tester to the spark plug cap.
3. Start the engine, and observe the sparks through the discharge window of the tester.

⚠ WARNING:

Do not touch any joint part of the lead wire of the tester. Keep away from inflammable gas or liquid, to prevent accident resulting from spark ignition.

SPARK PLUG CAP

1. Remove the spark plug cap. Check if the spark plug cap is broken. Replace if necessary.
2. Install the spark plug cap.
Turn it clockwise until it is tight.

FLYWHEEL MAINTENANCE

1. Use flywheel gripper to remove the nut and starter bush; use flywheel puller to remove flywheel.



2. Check if the flywheel is damaged or the permanent magnet part is firm. Replace if necessary.

CDI INSPECTION

CDI PEAK VOLTAGE

Use the digital circuit tester and peak voltage adaptor to measure CDI peak voltage. If below the specification, check the lead wire and measure the impulse and peak voltage output of the charge coil.



Digital circuit tester



Peak voltage adaptor

CDI peak voltage output	Start (load)	155V
	1500r/min	170 V
	3500r/min	170 V

NOTE:

If the impulse and peak voltage output of the charge coil are just same as or above the specification, and the CDI peak voltage output is below the specification, replace the CDI.

IGNITION COIL INSPECTION

1. Remove the ignition coil and spark plug cap.
2. Measure ignition coil resistance. Replace if out of the specification.
Resistance: 0.16~0.25 Ω (Tester (+) pole: orange wire; Tester (-) pole: black wire)
3.92~6.65k Ω (Tester (+) pole: orange wire; Tester (-) pole: high-voltage wire)

PULSED COIL INSPECTION

1. Pulsed coil peak voltage

Use the digital circuit tester and peak voltage adaptor to measure the peak voltage. If below the specification, check the pulsed coil resistance.



Digital circuit tester

Peak voltage adaptor

Pulsed coil peak voltage	Start (no-load)	4.0
	Start (load)	4.0
	1500r/min (load)	9
	3500r/min (load)	17V

2. Pulsed coil resistance

Measure the pulsed coil resistance. Replace if out of specification, replace.

Resistance: 234~348 Ω (Tester (+) pole: red/white wire; Tester (-) pole: black wire)

CHARGE COIL INSPECTION

1. Charge coil peak voltage

Use the digital circuit tester and peak voltage adaptor to measure the peak voltage. If below the specification, check the charge coil resistance.



Digital circuit tester

Peak voltage adaptor

Charge coil peak voltage	Start (no-load)	175V
	Start (load)	170V
	1500rpm	180V
	3500rpm	180V

2. Charge coil resistance

Measure charge coil resistance. Replace if out of specification.

Resistance: 272~408 Ω (Tester (+) pole: brown wire; Tester (-) pole: blue wire)

FUEL SYSTEM

NOTICE

Gasoline is inflammable and highly volatile liquid. Its leakage can cause fire and explosion. Don't start the engine before all joints of the fuel system are connected or installed. When completing all maintenance steps, force short-time pressure to the fuel system to check for leakage.

EXPLOSIVE DRAWING

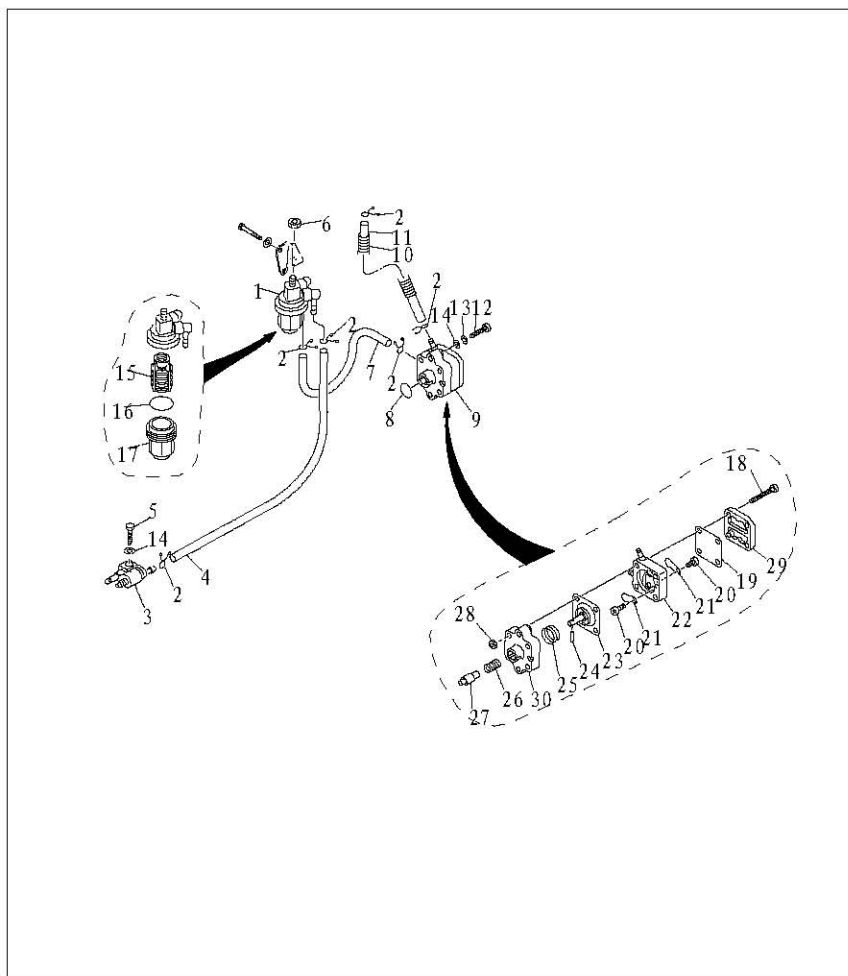

参照号码 SN.	零件编号 PART NO.	零件名称 DESCRIPTION	数量 QTY	备注 REMARKS
1	F15-07080000	滤油杯组件 FILTER ASSY	1	
2	F4-04000030	油管夹簧 B SPRING, FUEL PIPE "B"	6	
3	F4-05000200	燃油管接头组件 FUEL PIPE TIE-IN ASSY	1	
4	F15-05000016	燃油管 A $\varnothing 10 \times \varnothing 5 \times 0.5$ PIPE, FUEL A	1	
5	GB/T5783-M6x20	六角螺栓 M6x20 BOLT M6x20	1	
6	GB/T6170-M8	六角螺母 M8 NUT M8	1	
7	F15-07000027	油泵燃油管(进) HOSE (IN)	1	
8	JASO F44/A-24-021	燃油泵O形圈 O-RING	1	
9	F15-07140000	燃油泵组件 FUEL, PUMP ASSY	1	
10	F15-07000026	波纹管护套 JACKET	1	
11	F15-07000025	油泵燃油管(出) HOSE (OUT)	1	
12	GB/T823-M6x30	十字槽小盘头螺钉 M6x30 SCREW, SMALL PAN HEAD M6x30	2	

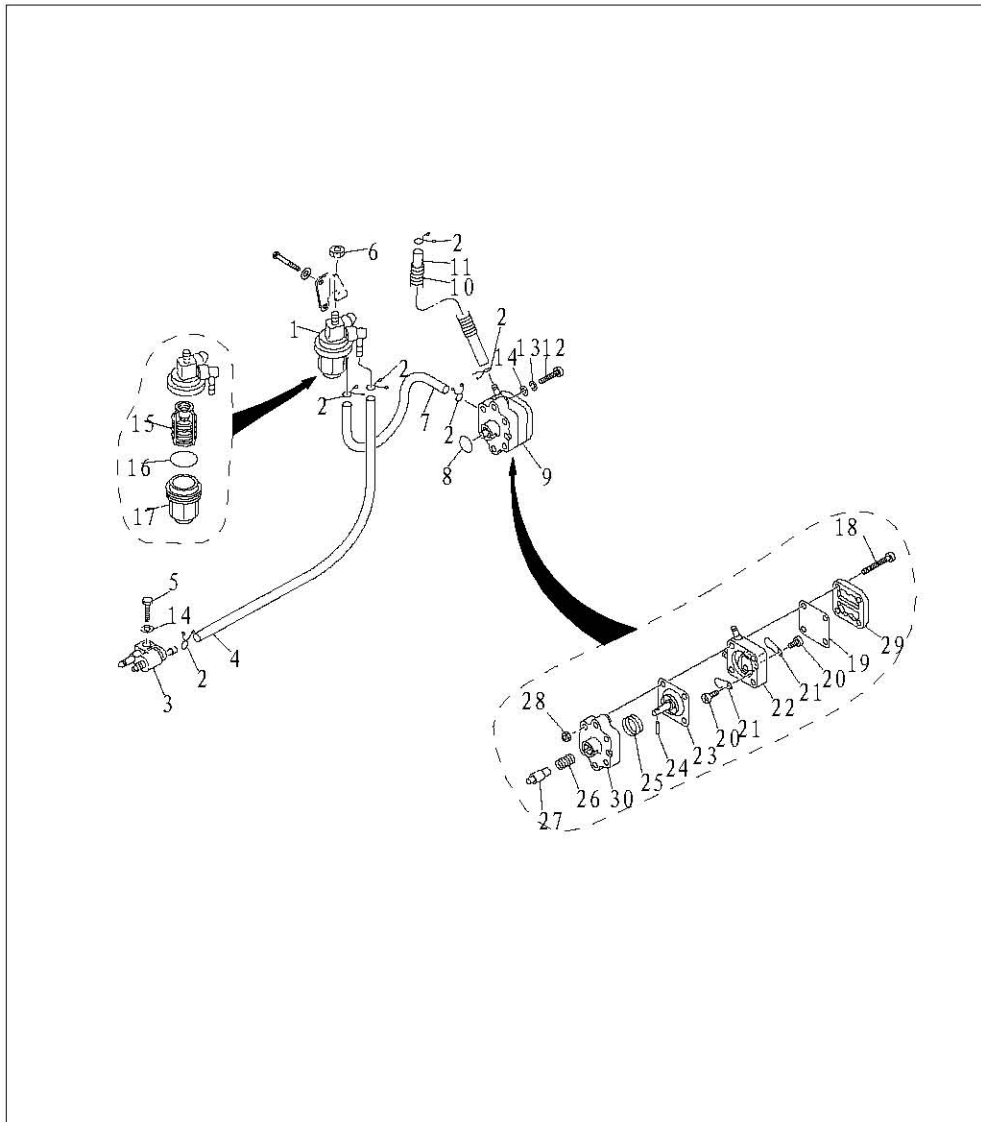

参照号码 SN.	零件编号 PART NO.	零件名称 DESCRIPTION	数量 QTY	备注 REMARKS
13	GB/T93-6	弹簧垫圈6 WASHER, SPRING 6	2	
14	GB/T97.1-6	平垫圈6 WASHER, PLATE 6	3	
15	F15-07080001	滤网罩 ELEMENT, FILTER	1	
16	GB/T3452.1-32.5x1.8	滤杯密封圈 φ 32.5x1.8 WASHER, CUP FILTER	1	
17	F15-07080002	滤杯 CUP, FILTER	1	
18	GB/T818-M4x30	十字槽盘头螺钉 M4x30 SCRRW, PAN HEAD M4x30	4	
19	F4-04090004	上隔膜 DIAPHRAGM, TOP	1	
20	F4-04090011	阀片螺钉M3x5 SCRRW, VALVE M3x5	2	
21	F4-04090005	单向阀片 PLATE	2	
22	F15-07140002	燃油泵壳 FUEL PUMP SHELL	1	
23	F15-07140100	隔膜组件 DIAP HRAGM ASSY	1	
24	GB/T309-3x12	滚针 φ 3x12 ROLLER NEEDLE	1	

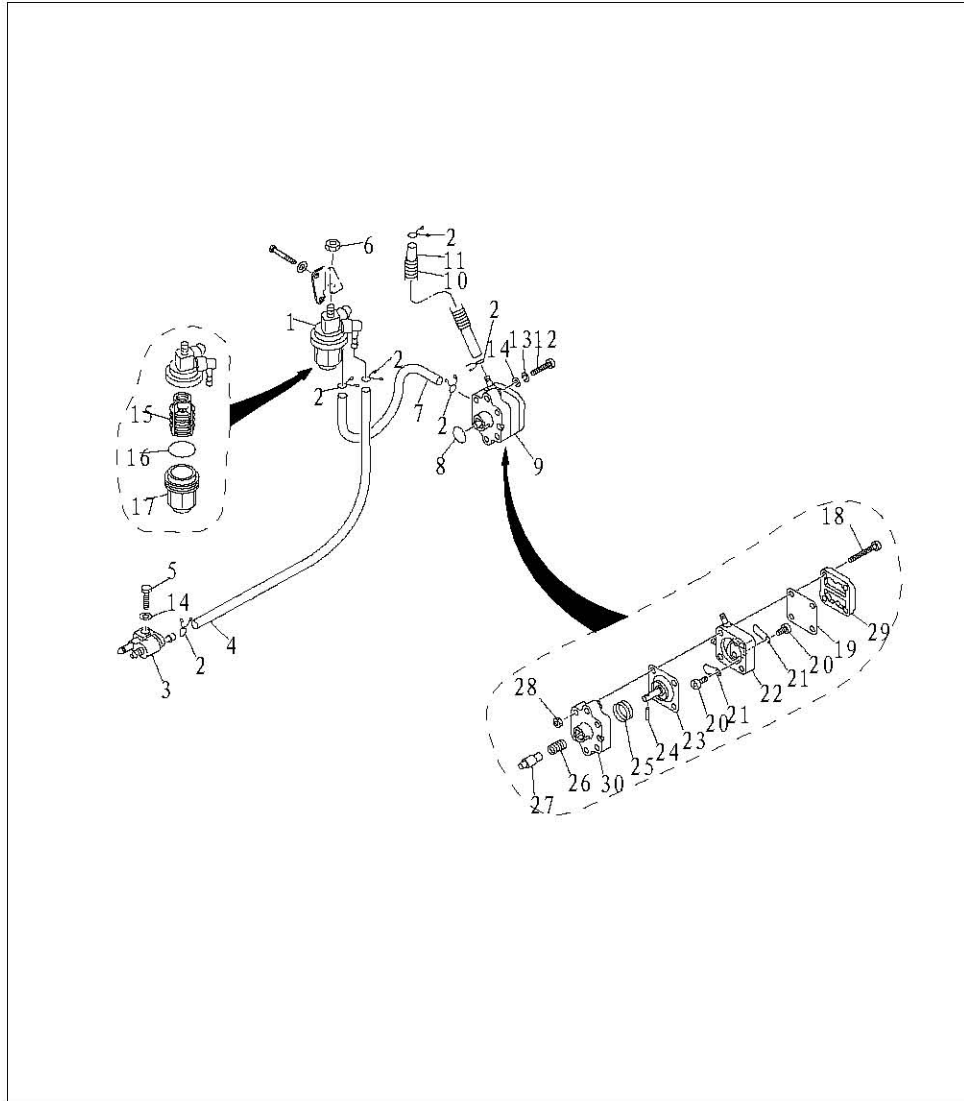

参照号码 SN.	零件编号 PART NO.	零件名称 DESCRIPTION	数量 QTY	备注 REMARKS
25	F15-07140005	隔膜弹簧 SPRING, DIAP HRAGEM	1	
26	F15-07140004	柱塞弹簧 SPRING, PLUNGER	1	
27	F15-07140003	柱塞 PLUNGER	1	
28	GB/T6170-20000	六角螺母 M4 NUT M4	4	
29	F4-04090003	燃油泵盖 COVER, FUEL PUMP	1	
30	F15-07140001	燃油泵座 SEAT, FUEL PUMP	1	

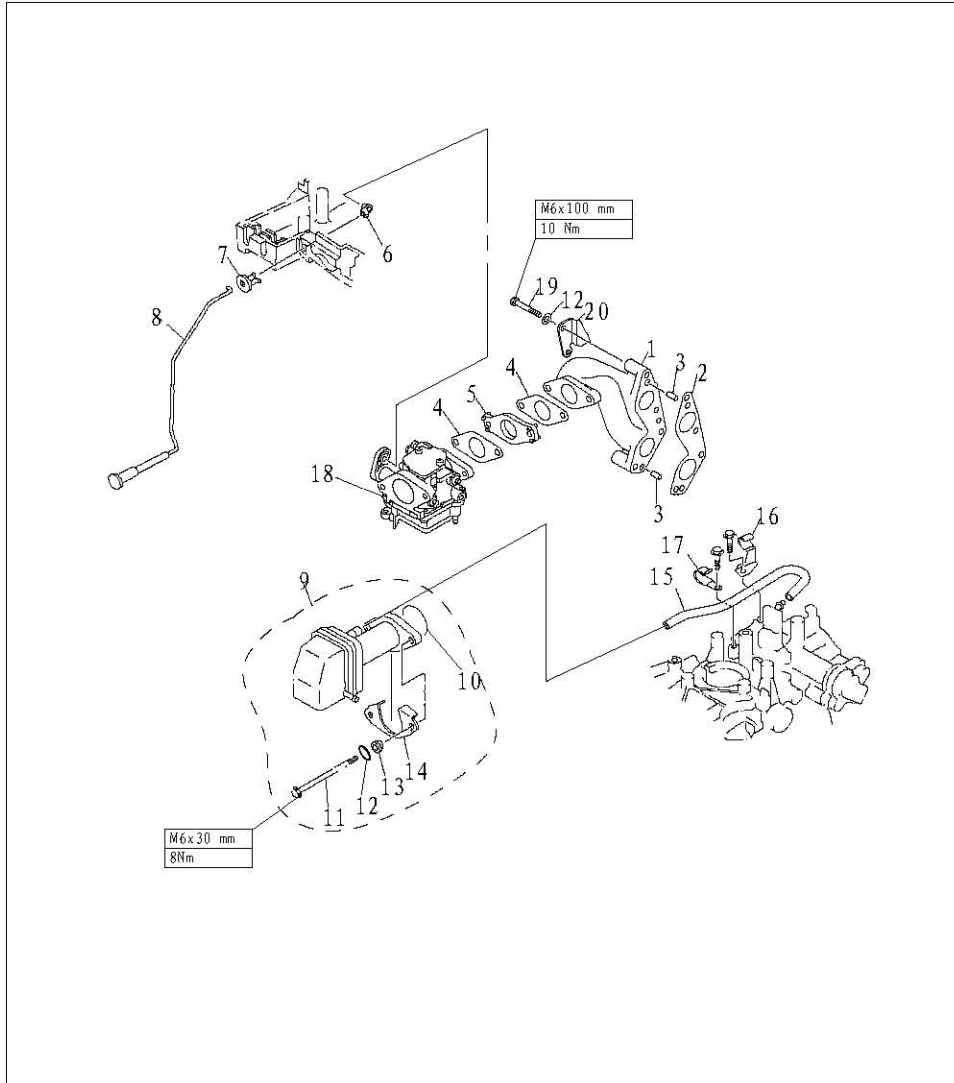

参照号码 SN.	零件编号 PART NO.	零件名称 DESCRIPTION	数量 QTY	备注 REMARKS
1	F15-07000008	进气歧管 MANIFOLD, INTAKE	1	
2	F15-07000007	进气歧管密封垫片 GASKET, MANIFOLD	1	
3	F15-00000006	定位销 $\phi 6 \times 12$ PIN, DOWEL $\phi 6 \times 12$	2	
4	F15-07000017	化油器纸垫 GASKET, CARBURETOR	2	
5	F15-07000018	化油器绝缘垫 INSULATOR, CARBURETOR	1	
6	F15-05010003	阻风门杆接头 JOINT, CHOKE LEVER	1	
7	F15-05010001	阻风门导向套 CASE, STARTER	1	
8	F15-05010100	阻风门杆组件 ROD, CHOKE	1	
9	F15-07100000	进气消音器组件 SILENCER ASSY, INTAKE	1	
10	GB3452.1-35.5x1.8	O型圈 35.5x1.8 O-RING 35.5x1.8	1	
11	GB/T5782-M6x100	六角螺栓 M6x100 HEXAGON BOLT M6x100	2	
12	GB/T97.1-6	平垫圈 6 WASHER, PLATE 6	6	

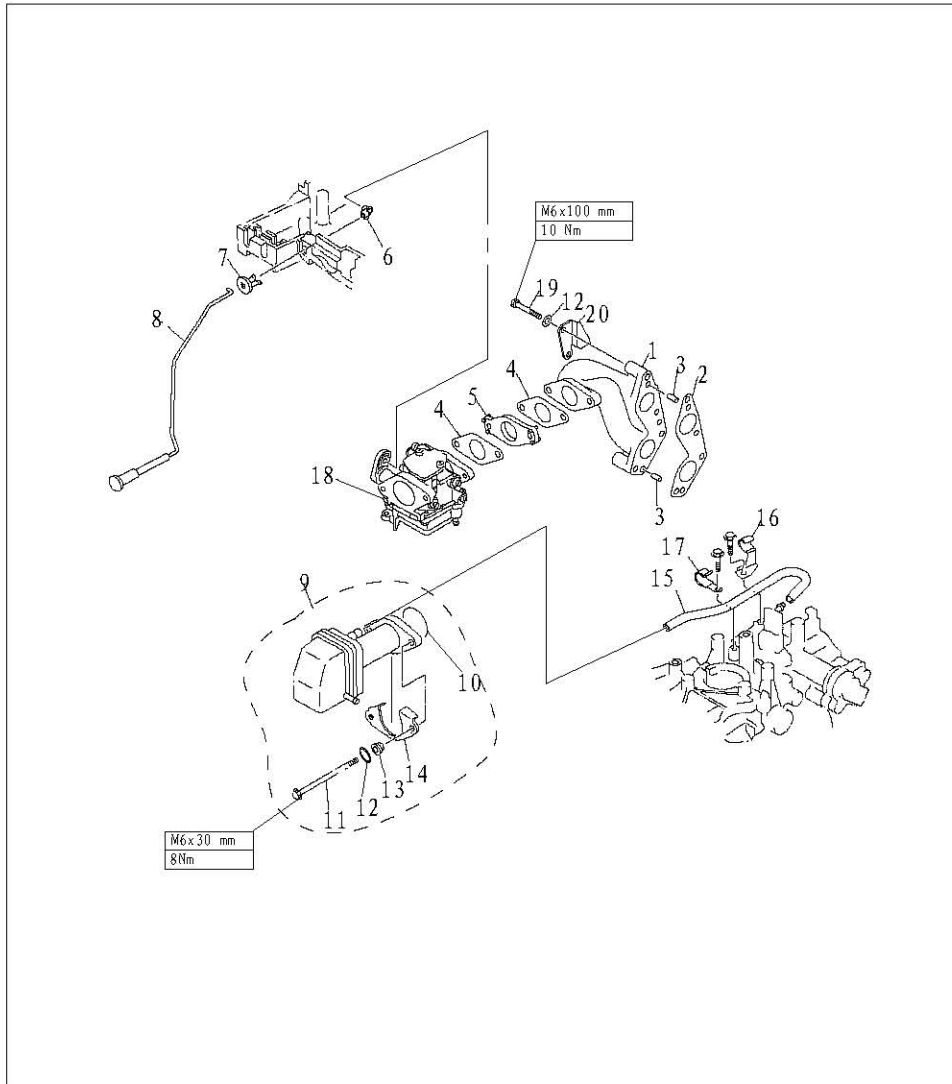

参照号码	零件编号	零件名称	数量	备注
SN.	PART NO.	DESCRIPTION	QTY	REMARKS
13	F15-07000021	进气消声器衬管 BUSHER, INTAKE SILENCER	2	
14	F15-07000022	进气消声器垫板 PLATE, INTAKE SILENCER	1	
15	F15-07010017	呼吸器弯管 PIPE, BREATHER	1	
16	F15-07010016	管卡 B CLAMP B	1	
17	F15-07010015	管卡 A CLAMP A	1	
18	F15-07090000	化油器 CARBURETOR	1	
19	GB/T5783-M6x40	六角螺栓M6×40 BOLT M6 × 40	4	
20	F15-07000009	滤油杯支架 BRACKET , OIL SIEVE	1	

Electric start type

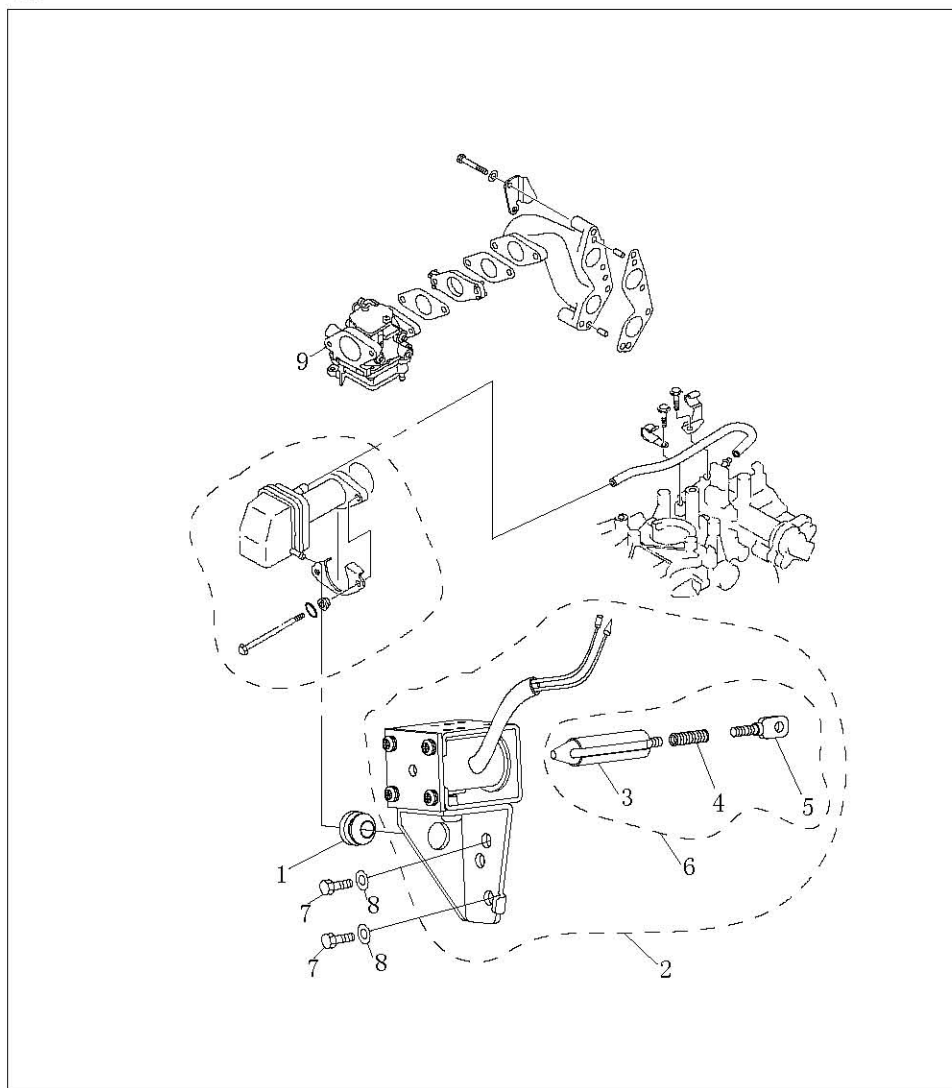

参照号码	零件编号	零件名称	数量	备注
SN.	PART NO.	DESCRIPTION	QTY	REMARKS
1	F4-0200011	变档轴密封圈	1	SEAL, SHAFT
2	F15-1103000W	电磁吸铁组件	1	ELECTROMAGNETIC MAGNET ASSY
3	F15-11030301W	铁芯	1	IRON CORE
4	F15-11030302W	铁芯连杆	1	LINK RAD, IRON CORE
5	F15-11030303W	铁芯拉头	1	HOOK, IRON CORE
6	F15-11030300W	吸铁铁芯组件	1	IRON CORE ASSY
7	GB/T5783-M6x12	六角螺栓M6x12	2	BOLT, HEXAGON M6x12
8	GB/T97.1-6	平垫圈6	2	WASHER 6
9	F15-07090000W	化油器总成	1	CARBURETOR

THROTTLE CONNECTING ROD ADJUSTMENT

1. Turn throttle accelerator enforce to full opening position.

Turn carburetor throttle rod to full opening position.

- 1 . Throttle accelerator enforce
- 2 . Carburetor throttle rod
- 3 . Lock screw

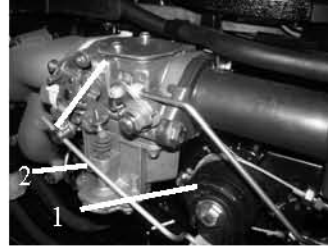

2. In full opening position, tighten the throttle rod lock screw.

FUEL JOINT REMOVAL AND INSPECTION

1. Remove the bolts fixing the fuel joint.
2. Remove the fuel joint.
3. Inspect the fuel joint for crack or damage.

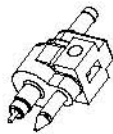

4. Connect the fuel joint exit with a vacuum pressure gauge.
5. Check whether the negative pressure can be maintained for over 10 minutes under the prescribed pressure. Replace if necessary.
Prescribed pressure: 50kPa.

FUEL PUMP REMOVAL AND INSPECTION

1. Remove the bolts fixing the fuel pump.
2. Remove the fuel pump.
3. Connect the fuel pump intake with a vacuum pressure gauge.
4. Block the exit of fuel pump with finger, and force a prescribed positive pressure to check for leakage.
Prescribed pressure: 50kPa
5. Force a prescribed negative pressure and check for leakage.
Prescribed pressure: 50kPa
6. Connect the fuel pump exit with a vacuum pressure gauge.

7. Force a prescribed negative pressure and check for leakage. Disassemble the fuel pump to check if necessary.
Prescribed pressure: 50kPa
8. Remove four bolts, and separate fuel pump cover from fuel pump seat.
9. Remove the valve screw from fuel pump, and remove the valve plate.
10. Press the plunger and diaphragm, rotate the fuel pump seat, and align the notch with the notch on the plunger. Take the roller needle out.
11. Inspect the diaphragm for crack and valve for damage. Replace if necessary.

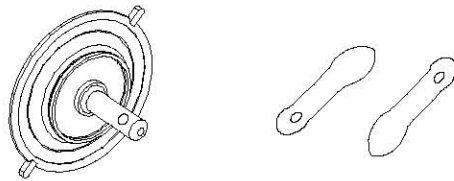

12. Reverse above step 8 to step 10 to install the fuel pump.

FILTER INSPECTION

Check if the filter element is clogged or with foreign matter. Check the filter cup for damage or leakage. Use gasoline to clean it, or replace if necessary.

NOTE:

Coat a layer of gasoline onto the O-ring before installing the filter cup.

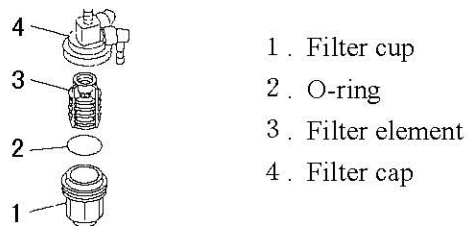

POWER UNIT

NOTICE

To avoid accidental start of outboard engine during maintenance, please take enough safety measures to disconnect the ignition system. For instance, remove the engine stop lanyard from engine stop switch assembly, and remove spark plug cap from spark plug.

EXPLOSIVE DRAWING

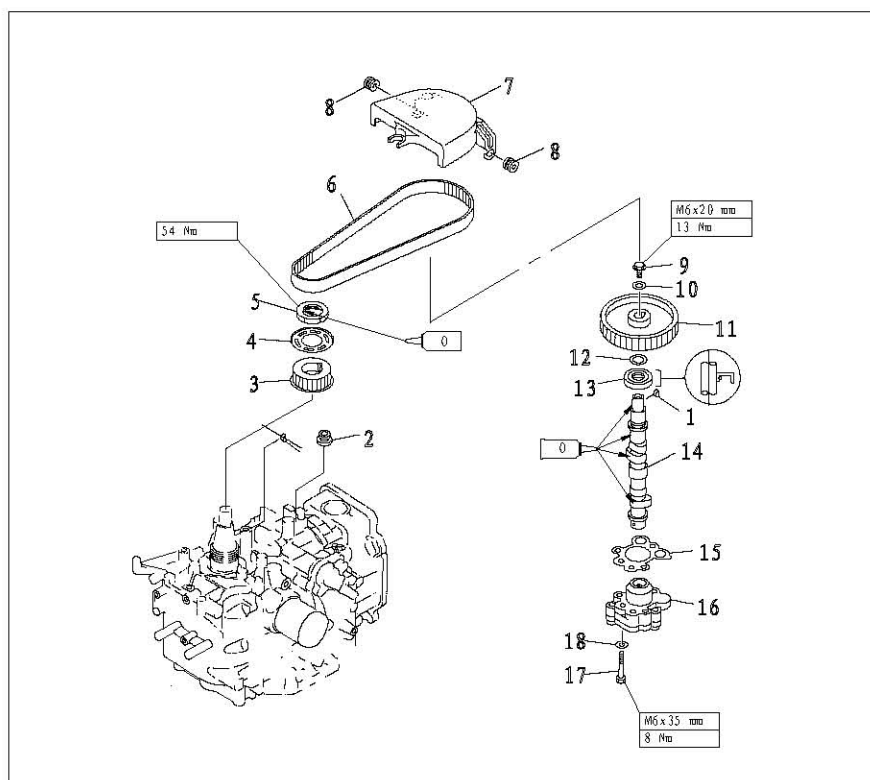

参照号码 SM.	零件编号 PART NO.	零件名称 DESCRIPTION	数量 QTY	备注 REMARKS
1	GB/T1099-1979	正时带轮半圆键	1	KEY, WOODRUFF
2	F15-07010027	带轮单橡胶圈 B	1	RUBBER RING B
3	F15-07030003	正时带轮	1	BELT PULLEY, TIMING
4	F15-07030004	正时带轮盖板	1	WASHER
5	F15-07030005	正时带轮螺母	1	NUT
6	F15-07000002	正时皮带	1	BELT, TIMING
7	F15-07000024	皮带罩壳	1	COVER, DUST
8	F15-07050003	带轮单橡胶圈 A	2	RING RUBBER A
9	GB/T5783-M6x16	六角螺栓M6x16	1	BOLT M6x16
10	GB/T5287-6	特大垫圈6	1	BIG WASHER 6
11	F15-07040018	从动带轮	1	BELT PULLEY, DRIVEN
12	F15-07040017	从动齿轮垫圈	1	WASHER
13	F15-07040008	油封 18X35X7-R	1	OIL SEAL 18X35X7-R
14	F15-07040200	凸轮轴组件	2	CAMSHAFT ASSY
15	F15-07040016	机油泵密封垫	4	MAT, OILPROOF
16	F15-07040500	机油泵总成	1	OIL PUMP ASSY
17	GB/T5783-M6x35	六角螺栓M6x35	3	BOLT M6x35
18	GB/T97.1-6	平垫圈6	3	WASHER 6

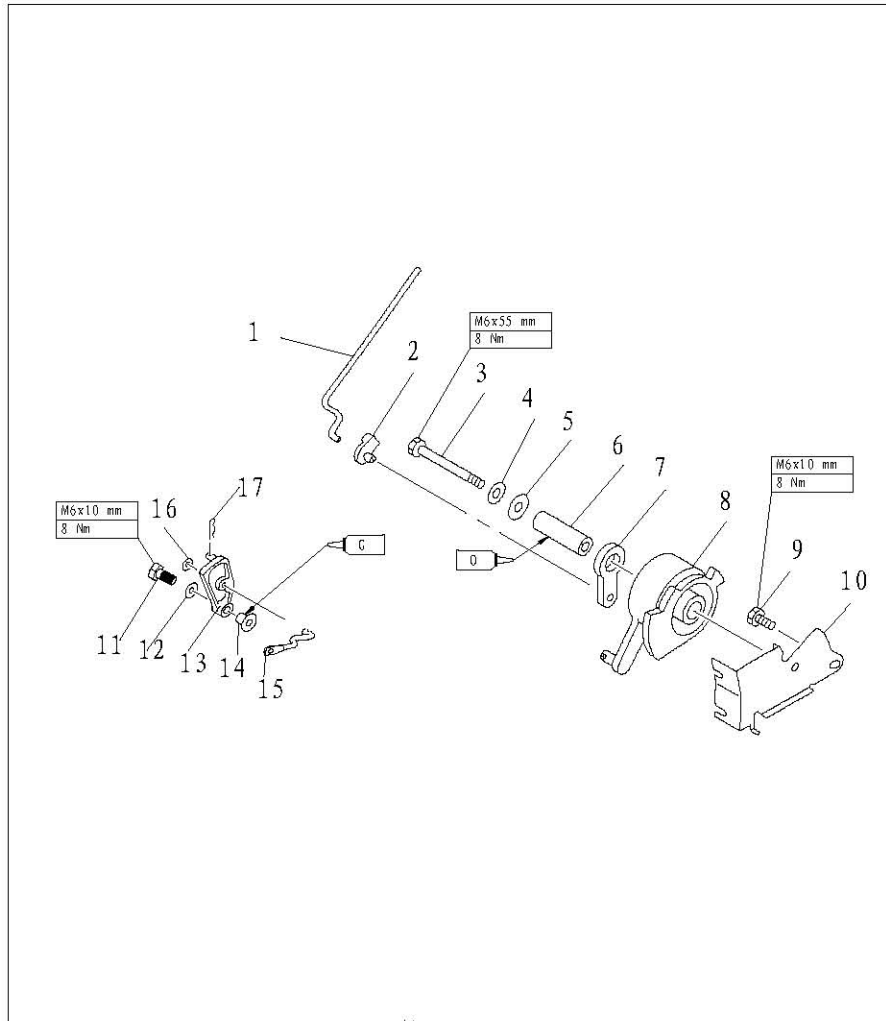

参照号码 SN.	零件编号 PART NO.	零件名称 DESCRIPTION	数量 QTY	备注 REMARKS
1	F15-07000015	油门控制器连杆 LINK , ACCELEROGRAPH CONTROL	1	
2	F15-07000016	油门控制器连杆接头 JOINT ACCELEROGRAPH CONTROL	1	
3	GB/T5782-M6x55	六角螺栓M6 × 55 BOLT M6 × 55	1	
4	GB/T97.1-6	平垫圈6 WASHER 6	5	
5	GB/T96-6	大垫圈6 LARGE WASHER 6	1	
6	F15-07000012	油门执行器衬管 BUSH , ACCELEROGRAPH ENFORCE	1	
7	F15-07000014	油门执行器从动滑轮 PULLEY , PASSIVITY	1	
8	F15-07000013	油门执行器主动滑轮 PULLEY , DRIVE	1	
9	GB/T5783-M6x10	六角螺栓M6 × 10 BOLT M6 × 10	1	
10	F15-07000011	控制钢索固定架 BRACKET , CONTROL TIGHTWIRE	1	
11	GB/T5783-M6x25	六角螺栓M6 × 25 BOLT M6 × 25	1	电起动型
12	GB/T5287-6	特大垫圈6 BIG WASHER 6	1	电起动型
13	F25-03000027W	换挡限位板 PLATE , SHIFT	1	电起动型
14	F25-03000028W	限位板衬管 BUSH , LIMITED PLATE	1	电起动型
15	F15-05040103W	换挡连接杆 LINK ROD , SEIFT	1	电起动型
16	F15-00000012	夹簧φ 1.8 SPRING	1	电起动型
17	GB/T96-5	大垫圈5 BIG WASHER 5	1	电起动型

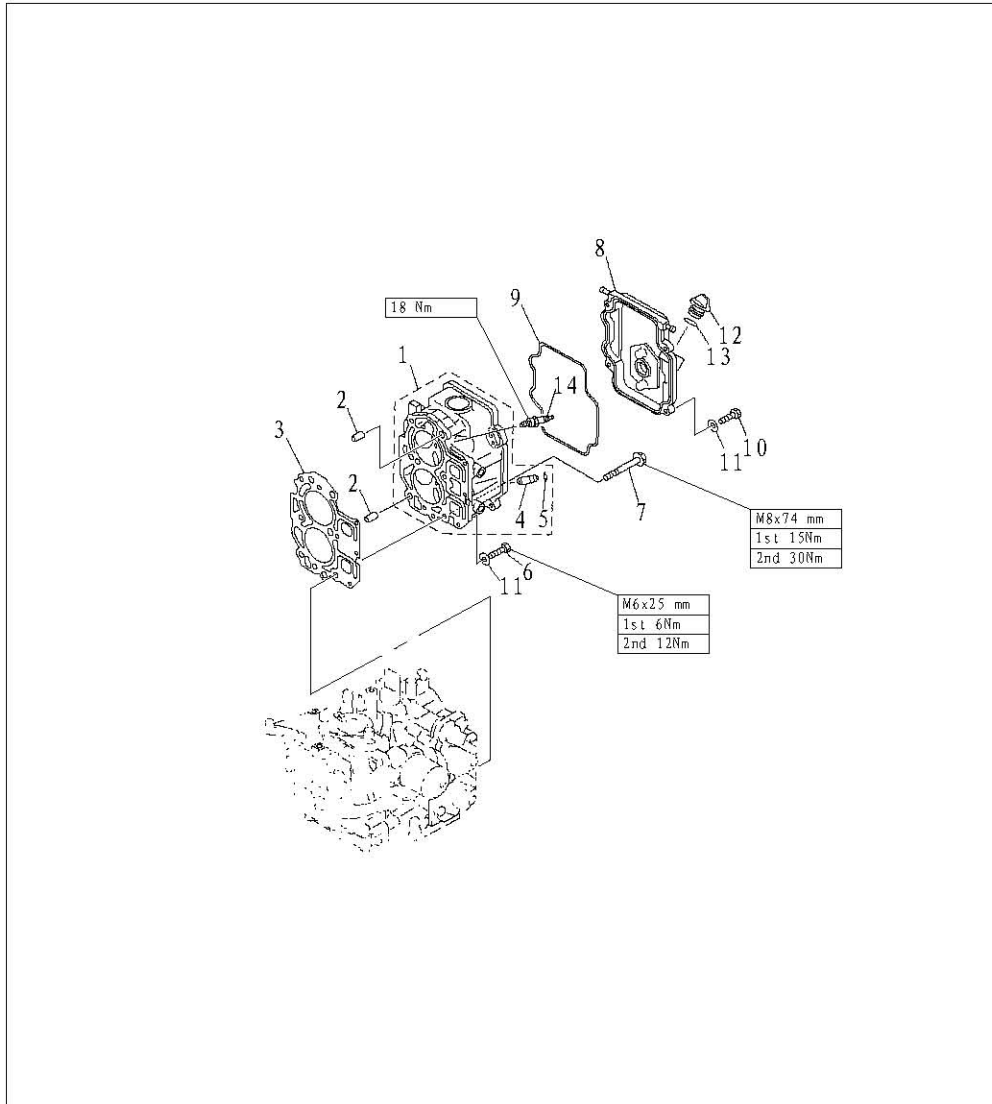

参照号码 SN.	零件编号 PART NO.	零件名称 DESCRIPTION	数量 QTY	备注 REMARKS
1	F15-07040100	气缸头组件 CYLINDER HEAD ASSY	1	
2	F15-07000001	空心定位销 $\phi 10 \times \phi 8.4 \times 14$ HOLLOW PIN	2	
3	F15-07000100	气缸垫组合 GASKET, CYLINDER HEAD	1	
4	F15-07040104	气门导管 VALVE GUIDE BUSH	4	
5	F15-07040105	气门导管卡圈 CIRCLIP, GUIDE BUSH	4	
6	GB/T5783-M6x25	六角头螺栓M6X25 BOLT, HEXAGON M6X25	3	
7	F15-07000028	六角头凸缘螺栓M8X75 BOLT, FLANGE M8X75	6	
8	F15-07050001	气缸头罩 COVER, CYLINDER HEAD	1	
9	F15-07050002	气缸头罩密封圈 SEAL, CYLINDER COVER	1	
10	GB/T5783-M6x20	六角头螺栓M6X20 BOLT, HEXAGON M6X20	4	
11	GB/T97.1-6	平垫圈6 WASHER, PLATE 6	7	
12	F15-07050004	加油口盖 PLUG, OIL	1	
13	JA80 P404 31-025	加油口盖O形密封圈 O-RING	1	
14	DPR7HS	火花塞 SPARK PLUG	2	

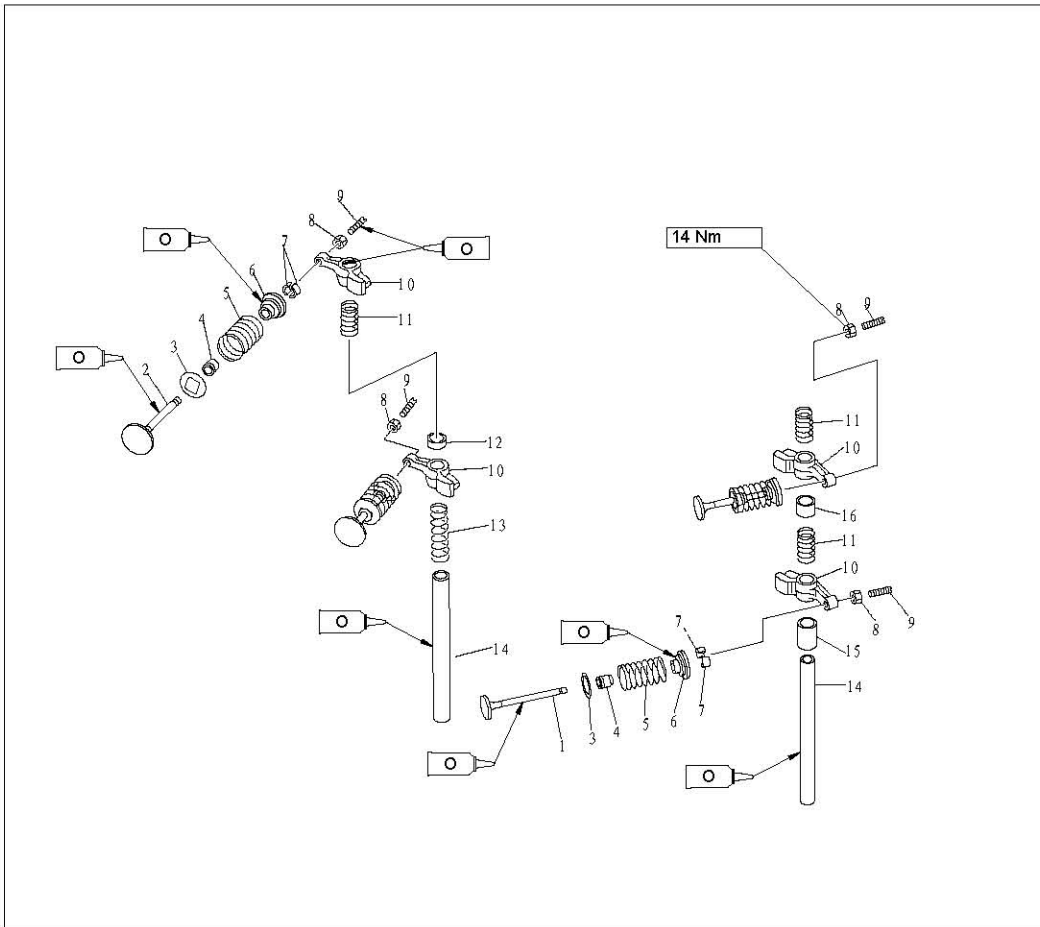

参照号码 SN.	零件编号 PART NO.	零件名称 DESCRIPTION	数量 QTY	备注 REMARKS
1	F15-07040001	进气门 VALVE, INTAKE	2	
2	F15-07040002	排气门 VALVE, EXHAUST	2	
3	F15-07040004	气门弹簧垫板 SEAL, VALVE SPRING	4	
4	PS2700, 04. 03	气门油封 SEAL, VALVE STEM	4	
5	F15-07040005	气门弹簧 SPRING, VALVE	4	
6	F15-07040006	气门弹簧座 RETAINER, VALVE SPRINGRE	4	
7	F15-07040007	气门弹簧卡圈 COTTER, VALVE	8	
8	F15-07040304	锁紧螺母 LOCK NUT	4	
9	F15-07040303	调整螺钉 SCREW, VALVE ADJUSTING	4	
10	F15-07040301	摇臂 ROCKER	4	
11	F15-07040014	摇臂轴弹簧B SPRING, ROCKER B	3	
12	F15-07040009	进气门垫管 BUSHER, VALVE INTAKE	1	
13	F15-07040013	摇臂轴弹簧A SPRING, ROCKER A	1	
14	F15-07040015	摇臂轴 SHAFT, ROCKER	2	
15	F15-07040012	排气门垫管B BUSHER, VALVE EXHAUST B	1	
16	F15-07040011	排气门垫管A BUSHER, VALVE EXHAUST A	1	

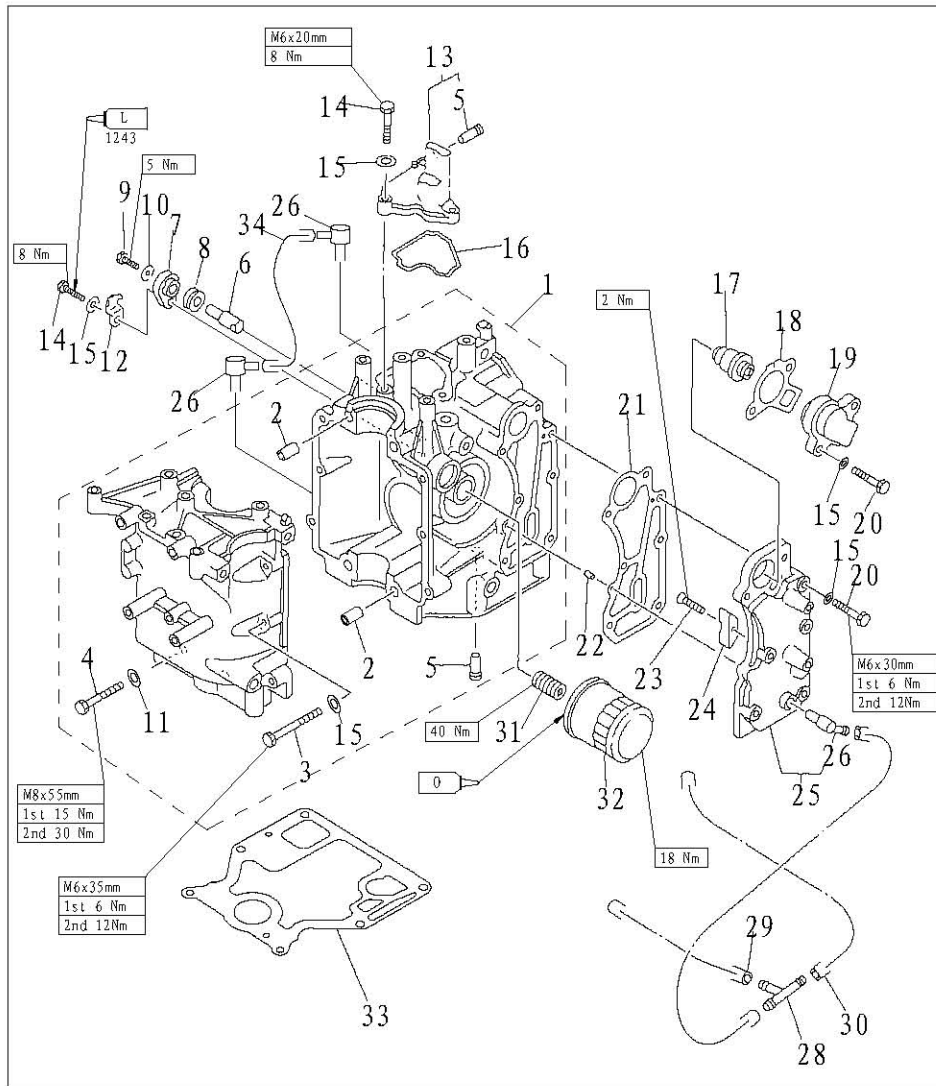

参照号码 SN.	零件编号 PART NO.	零件名称 DESCRIPTION	数量 QTY	备注 REMARKS
1	F15-07010000	机体机座组件 CRANKCASE ASSY	1	
2	F15-07000001	空心定位销 $\phi 10 \times 14$ IN, HOLLOW	2	
3	GB/T5783-M6x35	六角螺栓M6X35 BOLT, HEXAGON M6X35	6	
4	GB/T5783-M8x35	六角螺栓M8X55 BOLT, HEXAGON M8X55	4	
5	F15-07010006	吸油管接头 PIPE, JOINT	2	
6	F15-07010008	机体阳极 ANODE	1	
7	F15-07010011	阳极盖板 COVER, ANODE	1	
8	F15-07010009	阳极密封圈 GROMMET, ANODE	1	
9	GB/T5783-M5x12	十字槽盘头螺钉M5X12 SCREW, PAN HEAD	1	
10	GB/T97.1-5	平垫圈5 WASHER 5	1	
11	GB/T97.1-8	平垫圈8 WASHER 5	4	
12	F15-07010012	阳极锁止片 PLATE, ANODE	1	

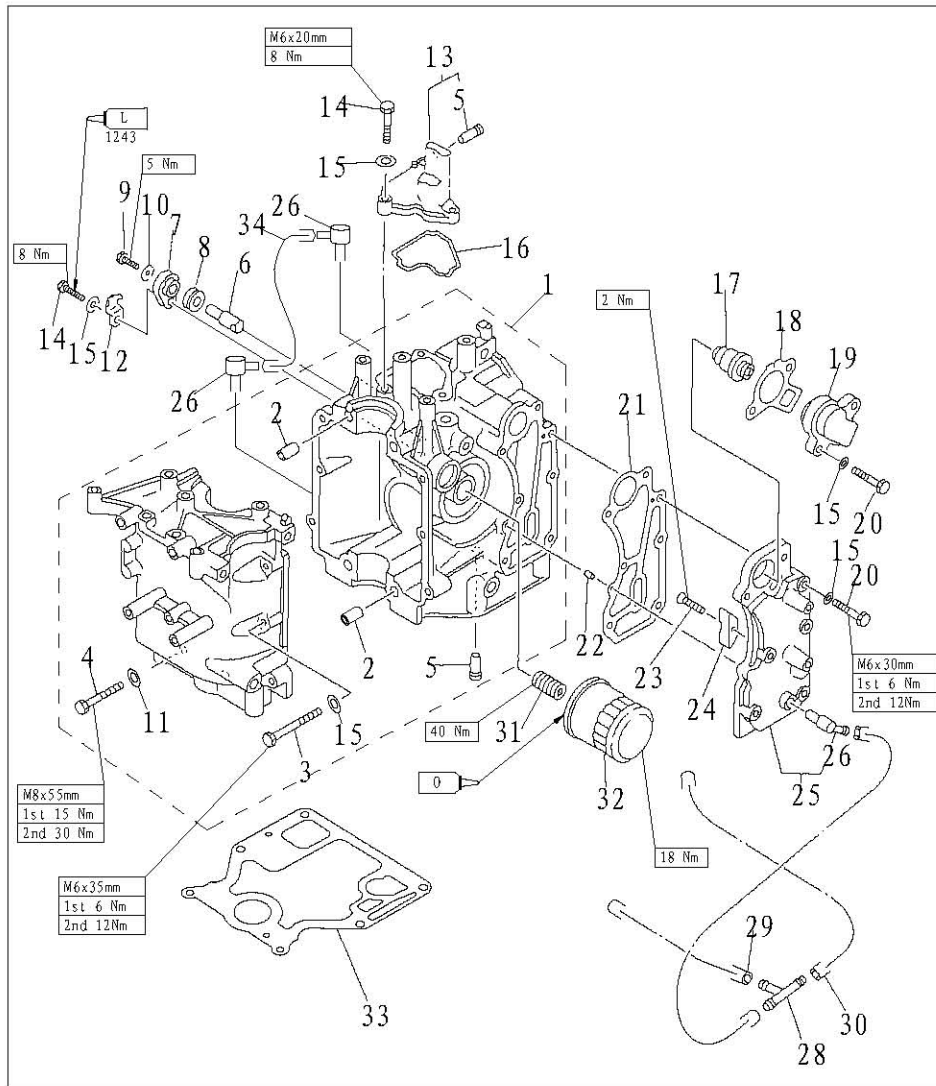

参照号码 SN.	零件编号 PART NO.	零件名称 DESCRIPTION	数量 QTY	备注 REMARKS
13	F15-07010013	呼吸器本体 COVER, BREATHER	1	
14	GB/T5783-M6x20	六角螺栓M6X20 BOLT M6X20	4	
15	GB/T97.1-6	平垫圈6 WASHER 6	17	
16	F15-07010014	呼吸器密封圈 BREATHER GASKET	1	
17	F15-04000036	节温器 THERMOSTAT	1	
18	F15-07010022	节温器盖垫 GASKET, THERMOSTAT	1	
19	F15-07010021	节温器盖 COVER, THERMOSTAT	1	
20	GB/T5783-M6x30	六角螺栓M6X30 BOLT M6X30	7	
21	F15-07010018	排气盖板垫 GASKET, EXHAUST OUTER COVER	1	
22	F15-00000013	定位销 $\phi 4 \times 12$ PIN	2	
23	GB/T820-M4x12	十字半沉头螺钉M4X12 SCREW	1	
24	F15-07010026	排气盖板阳极 ANODE	1	

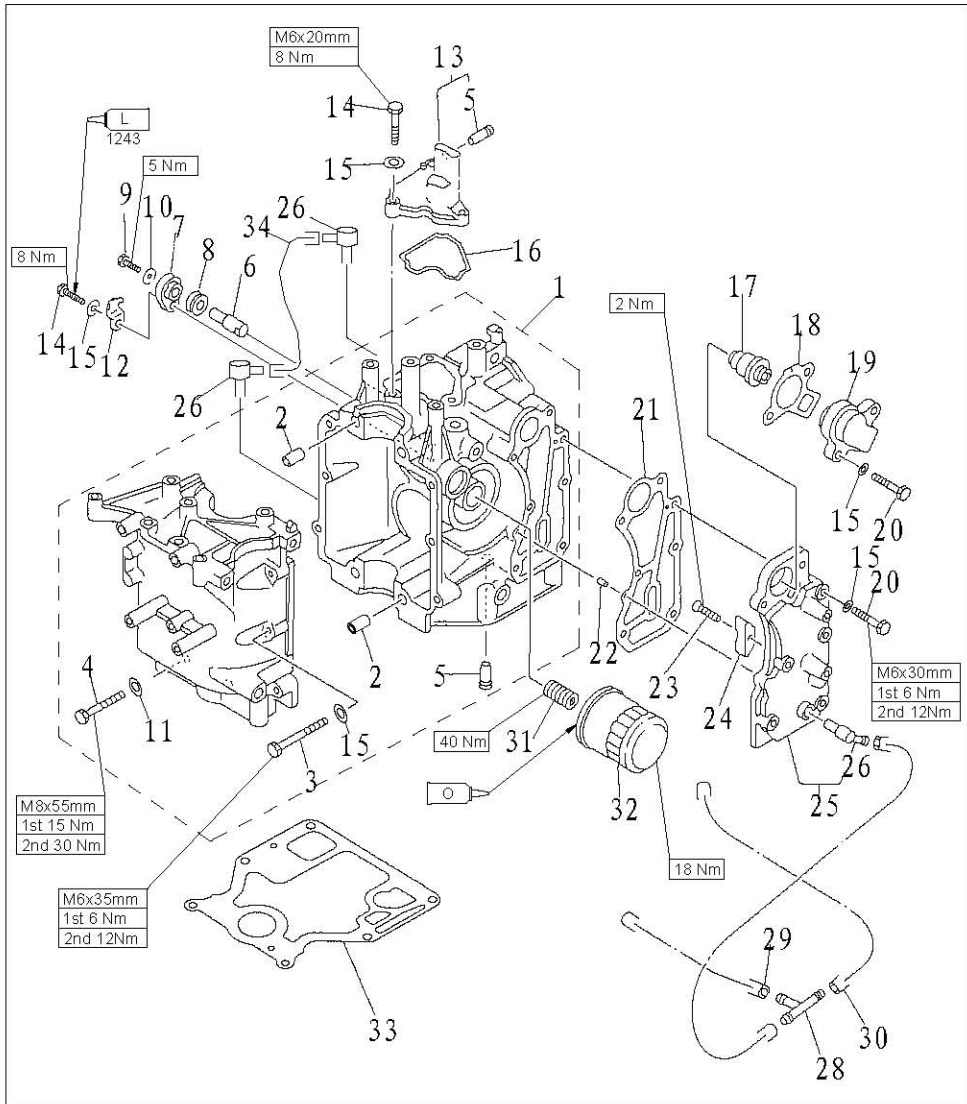

参照号码 SN.	零件编号 PART NO.	零件名称 DESCRIPTION	数量 QTY	备注 REMARKS
25	F15-07010019	排气盖板 OUTER COVER, EXHAUST	1	
26	F15-04000005	水嘴 WATER NIPPLE	3	
27	F15-05000012	水管 A $\phi 10 \times \phi 5 \times 67$ HOSE A	1	
28	F15-05000011	三通 THREE-WAY PIPE	1	
29	F15-05000013	水管 B $\phi 10 \times \phi 5 \times 172$ HOSE B	1	
30	F15-05000014	水管 C $\phi 10 \times \phi 5 \times 300$ HOSE C	1	
31	F15-07010003	机滤螺柱 BOLT UNION	1	
32	F15-07010023	机油滤清器 OIL CLEANER	1	
33	F15-00000014	发动机密封垫 GASKET, ENGINE	1	
34	F15-07010007	回油管 $\phi 10 \times \phi 5 \times 70$ HOSE, RETURN OIL	1	

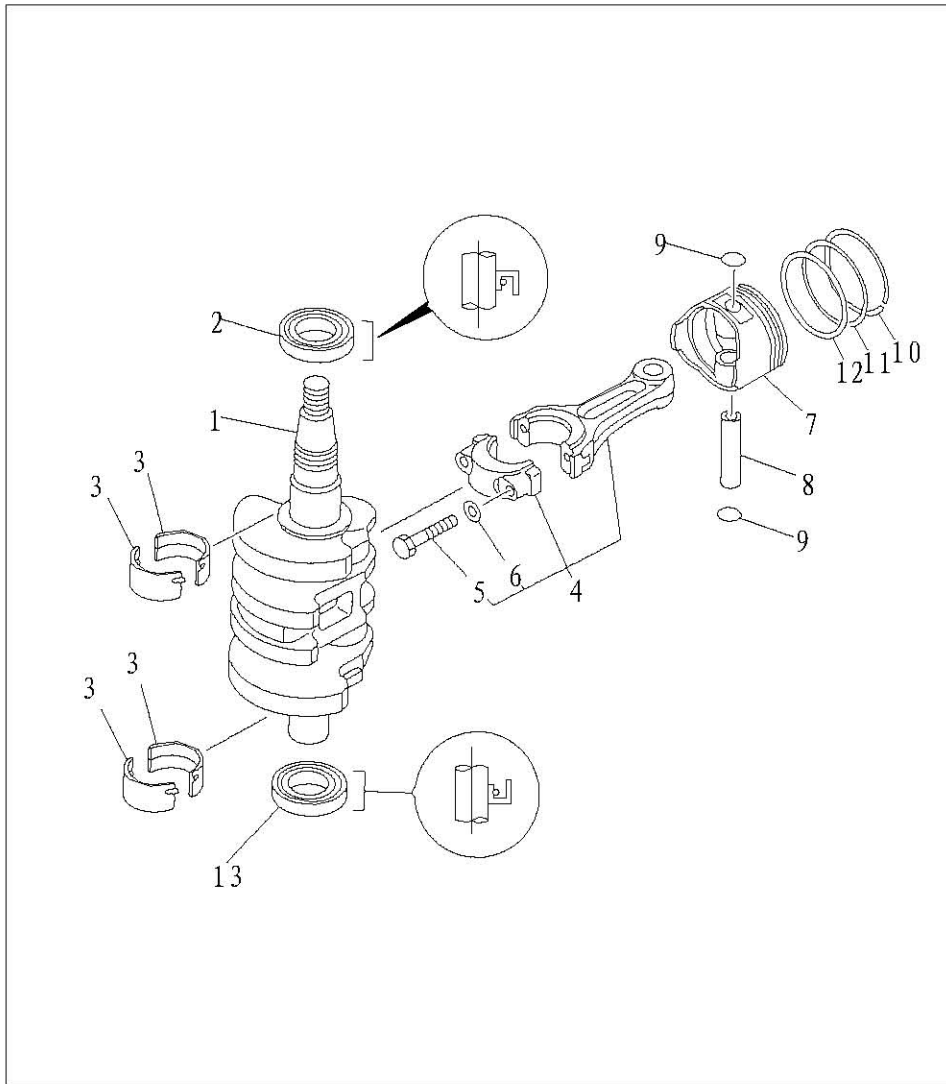

参照号码 SN.	零件编号 PART NO.	零件名称 DESCRIPTION	数量 QTY	备注 REMARKS
1	F15-07030000	曲轴组件 CRANK ASSY	1	
2	F15-07030006	曲轴油封 A 25x40x6.5-L OIL SEAL A	1	
3	F15-07010024	轴瓦 MAIN BEARING	4	
4	F15-07020100	连杆组件 ROD, CONNECTING	1	
5	F15-07020103	连杆螺栓 BOLT, CONNECTING ROD	2	
6	F15-07020104	连杆螺栓垫片 WASHER, PLATE	2	
7	F15-07020001	活塞 PISTON	1	
8	F15-07020006	活塞销 PIN, PISTON	1	
9	F15-07020005	活塞销挡圈 CIRCLIP	2	
10	F15-07020002	活塞环 I PISTON RING I	1	
11	F15-07020003	活塞环 II PISTON RING II	1	
12	F15-07020004	组合油环 COMBINATION OIL RING	1	
13	F15-07030007	曲轴油封 B 35x47x6.5-R OIL SEAL B	1	

SPECIAL TOOLS



Piston slider



Flywheel gripper and flywheel puller



Valve spring compressor



Housing oil seal installer

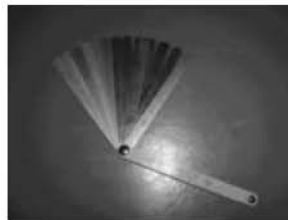

Space gauge



Oil cleaner spanner

COMPRESSION PRESSURE INSPECTION

1. Start the engine and preheat it for 5 minutes. Then stop it.
2. Remove stopper hang rope.
3. Remove spark plug and attach pressure gauge to spark plug hole.

CAUTION:

Before removing spark plug, use compressed air to clean the spark plug notch, to prevent dust and other foreign matter from entering cylinder.

4. Open the choke completely, and rotate the crankshaft with starter. When the pressure gauge readings become stable, check the cylinder pressure.

NOTE:

Please don't change the choke position when checking the cylinder pressure.

For models that use control box, remove the throttle link and open completely the carburetor throttle rod by hand, and then measure the pressure.

5. If the measured pressure is below the specification or there is difference between cylinders, add a little oil into cylinders and measure again.

NOTE:

If the cylinder pressure increases continuously, check piston and piston ring for damage. Replace if necessary.

If the cylinder pressure doesn't increase at all, check valve clearance, valve, valve seat, cylinder liner, cylinder cover and cylinder cover gasket. Adjust or replace if necessary.

The outboard engine comes with an automatic decompression device, so the pressure data measured may have variance.

OIL PRESSURE INSPECTION

1. Start the engine and preheat it for 5 minutes. Then stop it.
2. Remove the oil pressure switch and attach the pressure gauge.

NOTE:

Please use the pressure gauge equipped with 1/8in pitch thread adapter.

3. Check the oil pressure
Oil pressure (reference data): 110kPa (idling speed)

OIL PRESSURE SWITCH INSPECTION

1. Remove the oil pressure switch and attach the vacuum pressure gauge.
2. Load the stated pressure on oil pressure switch.
Inspect the continuity of oil pressure switch with digital circuit tester. Replace if unqualified.

Pressure	Continuity
Above 14.7kPa	Discontinuous
Below 14.7kPa	Continuous

3. When the engine rpm increases, check the opening pressure of the safety valve. Clean or replace if necessary.
Opening pressure: 388.0~450.0kPa

DISASSEMBLING POWER UNIT

1. Open the top cowling.
2. Remove starter.
3. Remove chokes cable and throttle cable.
4. Remove carburetor.
5. Remove flywheel with special tool.



Flywheel gripper and flywheel puller

6. Remove bolts connecting power unit and upper casing.
7. Lift the engine and remove the pin.
8. Remove oil strainer and safety valve.
Check the oil strainer for damage and clog. Replace if necessary.
Check the safety valve for damage and crack. Replace if necessary.
9. Remove the woodruff key.
10. Disconnect the engine stop switch wire and ground wire.
11. Remove throttle cable (manual start models) or cable joint (electric start models).
12. Remove charge coil, lighting coil and pulsed coil.
13. Remove high-pressure assembly, CDI unit, ignition coil, oil pressure switch and spark plug.

BELT PULLEY AND TIMING BELT

1. Rotate the flywheel clockwise. Align the mark '1' on the driven belt pulley with the mark "▼" on the cylinder cover.

CAUTION:

Please don't rotate the flywheel counter clockwise. Otherwise, valve system will be damaged.

2. Remove timing belt pulley nut with the special timing belt pulley nut barrel.

NOTE:

Please don't turn camshaft while unscrewing the timing belt pulley.

3. Remove timing belt from side of driven belt pulley.

CAUTION:

Please don't rotate the belt pulley before timing belt is fixed. Otherwise, valve system will be damaged.

4. Remove driven belt pulley bolt, driven belt pulley and woodruff key.

NOTE:

Please remove driven belt pulley bolt with flywheel gripper.

Please don't rotate camshaft while unscrewing the timing belt pulley.

5. Remove nut, limitative plate, timing belt pulley and woodruff key.

6. Check belt pulley and timing belt for crack, damage and wear. Replace if necessary.

7. Assemble woodruff key and driven belt pulley.

Align the mark "1" on the driven belt pulley with the mark "▼" on the cylinder cover. Tighten the driven belt pulley bolt temporarily.

CAUTION:

Please don't rotate the belt pulley before timing belt is fixed. Otherwise, valve system will be

damaged.

8. Assemble wood ruff key and timing belt pulley.

Align the notch mark on the timing belt pulley with the mark “▼” on the cylinder body.

9. Assemble new timing belt. Remember to put the timing belt part number vertical and upward.

CAUTION:

Please don't distort, rotate or bend the timing belt. Otherwise, it will be damaged.

Please keep timing belt from gasoline or oil.

Please don't rotate belt pulley counter clockwise. Otherwise, the valve system will be damaged.

10. Assemble limitative plate and tighten the nut temporarily.

11. Rotate timing belt pulley clockwise for two loops to eliminate the slack of timing belt pulley.
Check whether alignment marks are aligned well.

12. Tighten bolt and nut.

Locking torque: Driven belt pulley bolt 13.4 Nm

Timing belt pulley nut 54 Nm

NOTE:

Remove driven belt pulley bolt with flywheel gripper.

Tighten timing belt pulley nut with special timing belt pulley nut barrel.

DISASSEMBLING AND INSPECTION

CYLINDER COVER

Disassembling

1. Remove the bolts of cylinder head cover.
2. Remove the bolts of the cylinder cover according to the reverse numbering sequence marks on the cylinder cover.
3. Remove the cylinder cover. Remove the oil pump.
4. Remove the rocker arm shaft, spring and rocker arm assy.

NOTE:

Before removing rocker arm shaft, unscrew lock nut and adjust screw to slack.

5. Use the valve spring compressor to remove intake valve and exhaust valve.



Valve and valve guide bush

1. Inspect the valve seat width. If not in the prescribed range, repair the valve seat.
Valve seat width: 0.6~0.8mm

2. Inspect the valve margin thickness (T). If not as in the prescribed value, replace the valve.
The margin thickness of valve: 0.5~0.9mm

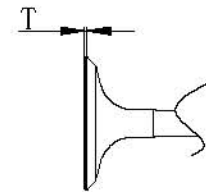

3. Inspect the valve stem diameter. If not in the prescribed range, replace the valve.
The diameter of valve stem:

Intake valve: 5.475~5.490mm

Exhaust valve: 5.460~5.475mm

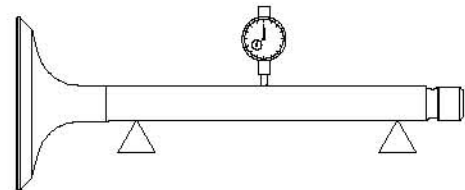

4. Measure the valve stem run out. If exceeding the limit, replace the valve.
Valve stem run out limit: 0.01mm

5. Measure the inside diameter of the valve guide bush.
The inside diameter of the valve guide bush: 5.500~5.512mm

CAUTION:

When replacing the valve, use a new valve guide bush and valve oil seal.

Valve spring

1. Measure the free length of valve spring. If less than prescribed value, replace.
The minimum free length: 32.68mm
2. Measure the valve spring tilt. If exceeding the prescribed limit, replace.
The maximum tilt limit: 1.5mm

Valve rocker arm and rocker shaft

1. Check the interface between the valve rocker arm and rocker shaft for wear. Replace if necessary.
2. Measure whether the inside diameter of valve rocker arm and outside diameter of rocker shaft are within prescribed value.
The inside diameter of valve rocker arm: 13.000~13.018mm
The outside diameter of rocker shaft: 12.941~12.951 mm

Camshaft

1. Check the camshaft size.

Replace if necessary.

Height	Intake camshaft	27.596~27.696mm
	Exhaust camshaft	27.616~27.716mm
Base circle diameter		23.950~24.050mm

2. Check camshaft run out. Replace if necessary.
Roundness limit: 0.03mm

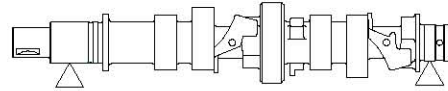

3. Check main journal diameter of camshaft and journal inside diameter of cylinder cover. Replace if necessary.
Journal inside diameter of cylinder cover: 35.000~35.012mm
Main journal diameter: 34.935~34.955mm
4. Check the automatic decompression device for crack and damage. Replace the camshaft if necessary.

Oil pump check

1. Remove screw and oil pump.
2. Check rotor clearance of oil pump. Replace if out of specification.

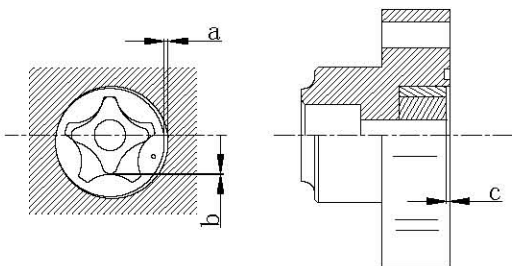

Clearance between external rotor and casing a	0.100~0.150 mm
Clearance between external rotor and internal rotor b	0.040~0.140 mm
Clearance between rotor and cover c	0.030~0.090 mm

Valve guide bush replacement

1. Knock out the valve guide bush from the direction of combustion room.
2. Knock in the new valve guide bush from the direction of the top of cylinder cover.

NOTE:

Coat the oil on the surface of pipe before installation.

3. Bore the inside diameter of pipe to the prescribed value by reamer.
Inside diameter of valve pipe: 5.500~5.512mm

NOTE:

When taking out the reamer, don't rotate it in counter clockwise direction.

Valve seat inspection

1. Clean the carbon on the valve.
2. Coat a thin layer of bluing dye evenly onto the seal face of the valve seat.

3. Lap the valve on valve seat by valve lapping tool.
4. Measure the valve seat width.
The valve face is with bluing dye.
If the valve and valve seat do not match, or the valve seat width does not conform to specified value, reface and lap the valve seat.
If the contact surface is not even, replace the valve guide bush.
The valve seat width: 0.6~0.8mm
The maximum valve seat width: 1.1mm

Valve seat cutting

1. Use 45° valve seat cutter to adjust the valve seat width. Turn the cutter clockwise until the valve seat face is smooth.
2. If the valve seat is centered on the valve face but it's too wide, to reduce the valve seat width, use 30° cutter to adjust the top edge of the seat, and use 60° cutter to adjust the bottom edge of the seat.

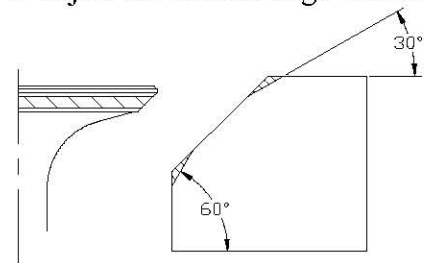

3. If the valve seat is too narrow and on the top edge of valve surface, use 30° cutter to adjust the top margin of the seat, and use 45° cutter to adjust the valve seat width if necessary.

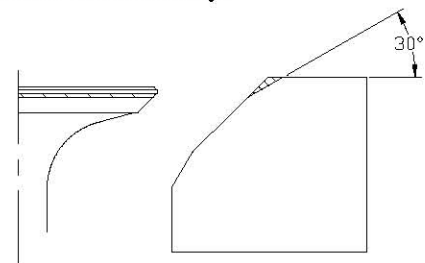

4. If the valve seal surface is too narrow and on the bottom edge of valve surface, use 60° cutter to adjust the bottom edge of the seat, and use 45° cutter to adjust the valve seat width if necessary.

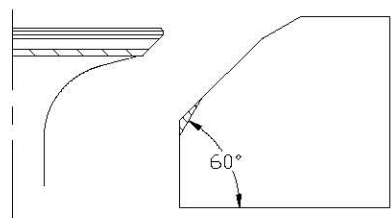

5. Coat evenly a thin layer of lapping compound onto valve seat, and lap the valve by lapping tool.
6. Clean up the remaining lapping compound.
7. Inspect again the valve seat width.

CAUTION:

Do not overlap the valve. Turn the lapping tool evenly with a downward force of 40~50N. Do not contaminate push rod and valve guide bush with lapping compound.

Valve installation

1. Install new valve oil seal and spread engine oil to the valve guide bush.
2. Install valve, valve spring seal, valve spring and valve spring retainer in sequence.
3. Compress the valve spring with valve spring compressor and install valve cotter.
4. Knock valve spring retainer slightly with plastic or rubber hammer to fix the valve cotter.

Assembling cylinder cover

1. Install new oil seal with special tool.
2. Install camshaft into cylinder cover from the direction of oil pump.
3. Check whether spline position is facing the conjunction surface of cylinder. Adjust if necessary.
4. Install rocker arm assembly, spring and rocker shaft.
5. Assemble oil pump.

NOTE:

Ensure mark on the external rotor is facing the oil pump cover.

6. Align oil pump drive shaft with camshaft pin, then install oil pump.

CAUTION:

Before installing oil pump, make sure the oil passage is through, and fill the oil pump with oil.

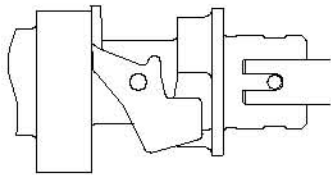

CRANKCASE

Disassembling

1. Remove the oil cleaner with special tool.

NOTE:

Put one piece of cloth under oil cleaner



Oil cleaner spanner

2. Remove thermostat cover and gasket.
3. Remove exhaust outer cover, gasket and pin.
Clean the anode surface and check the anode. Replace if the corrosion of anode is abnormal.
Check the exhaust outer cover for crack, distortion or corrosion. Replace if necessary.
4. Remove breather.
Check the breather body for crack, distortion or corrosion. Replace if necessary.
5. Remove the crankcase bolts according to below drawing, and remove the crankcase.

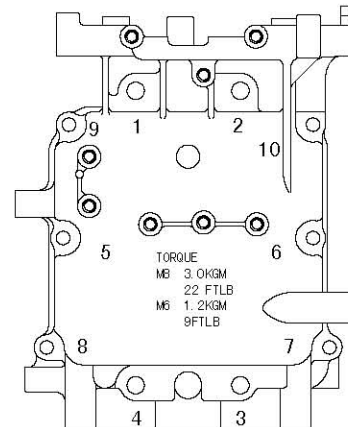

6. Remove the connecting rod bolts and connecting rod cover, remove the crank, and remove connecting rod and piston assy.
7. Remove piston pin circlip with pliers, and remove piston pin and piston.
8. Remove oil seal, pin and main bearing.

Piston

Measure piston outside diameter at the specified measuring point.
If out of specification, replace.
Piston diameter: 58.950~58.965mm
Measuring point@: 5mm

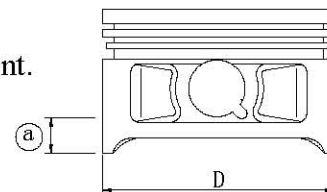

Cylinder bore

1. Measure cylinder bore separately at measuring point ①, ②, ③.
At each point, measure the cylinder bore at places D1, D3, D5 parallel to the crankshaft and at places D2, D4, D6 vertical to the crankshaft.

Measuring point height: ① 10mm;
② 40mm;
③ 70mm

Cylinder bore: 59.00~59.02mm
Limit size: 59.10mm

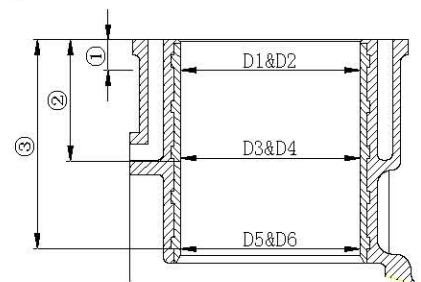

2. Calculate taper limit and round limit. If out of specification, replace crankcase.

Taper limit: 0.08mm (D1-D5, D2-D6)

Round limit: 0.05mm (D2-D1, D6-D5)

Piston pin outside diameter

Measure piston pin outside diameter. If out of specification, replace the piston pin.

Piston pin outside diameter: 13.996~14.000mm

Piston ring

1. Push the piston ring parallel with the piston into the specified measuring point of the cylinder (10mm from conjunction surface).

2. Measure end gap by space gauge. If out of specification, replace the piston ring.

End gap (installed):	Top ring	0.15~0.30mm
	2nd ring	0.30~0.50mm
	Oil ring	0.2~0.7mm

3. Install piston ring to piston, and measure side clearance between piston ring and its slot by space gauge. If out of specification, replace the piston ring.

Side clearance:	Top ring	0.04~0.08mm
	2nd ring	0.02~0.04mm
	Oil ring	0~0.22mm

Crankshaft

1. Measure diameter of crankshaft main journal, crankpin diameter and crankpin width. If out of specification, replace the crankshaft.

Diameter of crankshaft main journal	34.997~35.009 mm
Crankpin diameter	30.997~31.009 mm
Crankpin width	21.00~21.07mm

2. Measure crankshaft run out. If out of specification, replace.

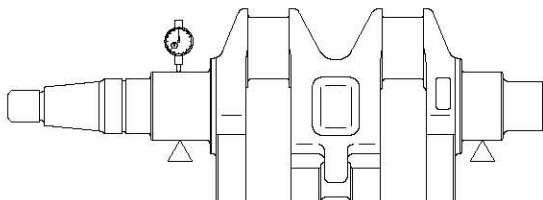

Crankshaft run out limit: 0.05mm

Crankpin oil clearance

1. Put a piece of plastic space gauge on to the crankpin in parallel to the crankshaft.

2. Assemble connecting rod to the crankpin.
3. Tighten the connecting rod bolts to the specified torque.
Tightening torque: First tightening 10 Nm
 Second tightening 21 Nm
4. Remove the connecting rod, measure the compressed width of the plastic space gauge. If out of specification, replace the connecting rod.
Oil clearance: 0.020~0.052mm

NOTE:

Don't rotate the connecting rod before completing measurement.

Main journal oil clearance

1. Clean main bearing, main journal and fitting surface of cylinder body and crankcase.
2. Install main bearing and crankshaft to cylinder body.
3. Put one plastic space gauge on the main journal, paralleling with crankshaft.

NOTE:

Don't put plastic space gauge on the oil hole of main journal.

4. Install main bearing onto crankcase and install crankcase onto cylinder body.
5. Following the numbering sequence on the crankcase, tighten the bolts at specified torques.
Tightening torques:

First tightening	M8	15 Nm
Second tightening		30 Nm
First tightening	M6	6 Nm
Second tightening		12 Nm

6. Remove crankcase and measure the compressed width of each plastic gauge. If out of specification, replace the main bearing.
Oil clearance: 0.012~0.045mm

NOTE:

Please don't rotate the crankshaft before the measurement is completed.

Cylinder body and crankcase

1. Inspect cylinder body and crankcase for crack, damage or wear. Replace if necessary.
2. Inspect cooling water passage for dirt or clog. Clean if necessary.

FULL INSTALLATION

Piston connecting rod installation

Install piston, connecting rod, piston pin and piston pin circlip

NOTE:

When installing, make sure that the mark on the connecting rod is on the same side as the mark on the piston crown.

Piston ring installation

1. Install oil ring, 2nd ring and top ring.

NOTE:

Make sure that the mark is toward the piston crown when installing the 2nd ring.

2. Picture of the piston ring gap

- Oil ring end gap 1 (lower rail)
- Oil ring end gap 2 (expanded ring)
- Oil ring end gap 3 (upper rail)
- 2nd piston ring end gap 4
- Top piston ring end gap 5

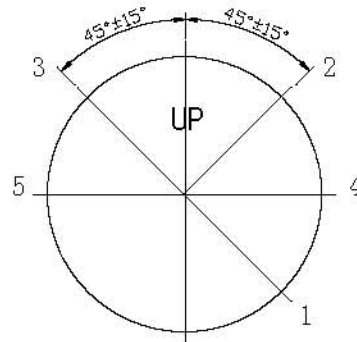

Piston installation

Use piston slider to install piston, and make sure that the piston crown "UP" is toward the flywheel side.



NOTE:

Apply engine oil to the piston and piston ring side when installing.

Crankshaft installation

1. Install the crankshaft and main bearing to cylinder body. Install oil seal.

NOTE:

Apply grease onto new oil seal before installing.

2. Install connecting rod cover, and tighten the connecting rod bolt to the specified torque.

- Tighten torque: First tightening 10 Nm
- Second tightening 21Nm

NOTE:

Apply engine oil to moving parts before installing.

Assembling power unit

1. Install the main bearing to cylinder body.
2. Apply fluid sealant to conjunction surface of the cylinder body, and install dowel pin and cylinder body. Tighten the bolts twice according to the sequences on the right picture.
Tighten torque

First tightening	M8	15 Nm
Second tightening		30 Nm
First tightening	M6	6 Nm
Second tightening		12 Nm

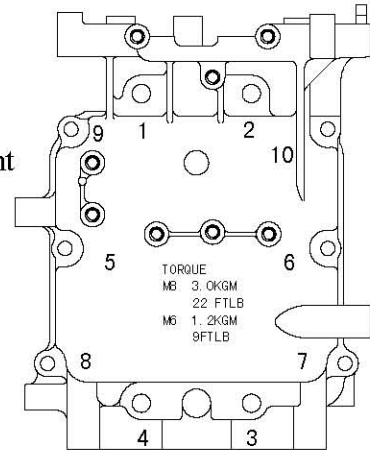

NOTE:

Apply engine oil to moving parts before installing.

3. Install bolt union of oil cleaner and tighten it to the specified torque.
Tighten torque: 40 Nm
4. Install breather.
5. Install exhaust outer cover, thermostat and thermostat cover.
Tighten bolts twice according to priority as picture.
Tighten torque: First tightening 6 Nm
Second tightening 12 Nm

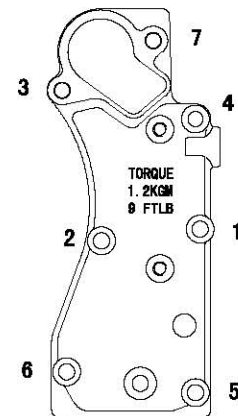

6. Install dowel pin, cylinder gasket and cylinder cover assembly.
7. Inspect the position of woodruff key slot.
8. Tighten the cylinder cover bolts twice to specified torque according to sequences on right picture.
Tighten torque:

First tightening	M8	15 Nm
Second tightening		30 Nm
First tightening	M6	6 Nm
Second tightening		12 Nm

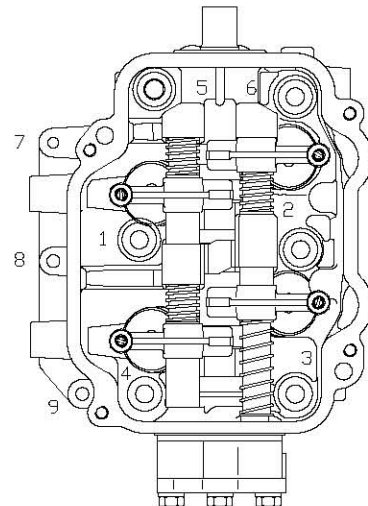

9. Install timing belt pulley, driven belt pulley, timing belt and breather pipe.
10. Adjust valve clearance.

11. Install cover of cylinder cover and tighten bolt according to sequences on right picture.
12. Install throttle cable bracket and accelerograph enforce.
13. For electric start models, install gear shift limitative rod firstly.
14. Install oil pressure switch, ignition coil, C.D.I. unit assy. and rectifier and regulator assy.
15. Install pulsed coil, lighting coil and charge coil.
16. Install fuel system.
17. Install pressure relief valve and oil strainer.

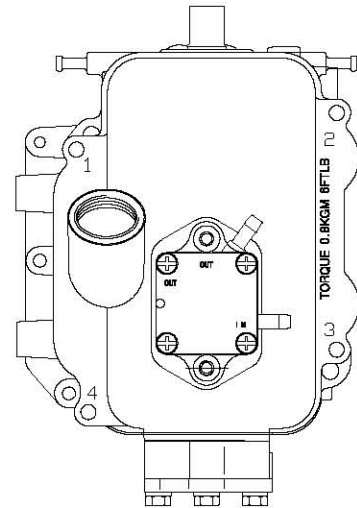

UPPER UNIT TOP COWLING

Explosive drawing

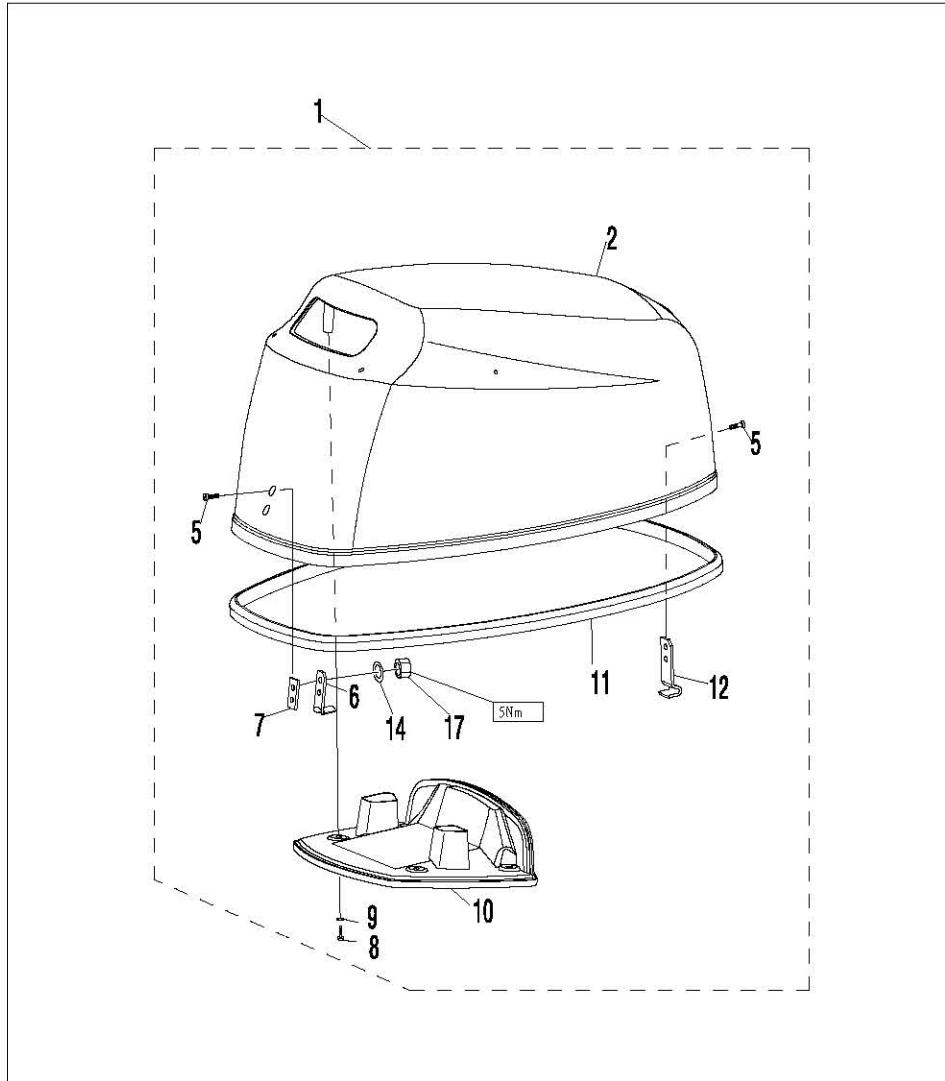

参照号码 SN.	零件编号 PART NO.	零件名称 DESCRIPTION	数量 QTY	备注 REMARKS
1	F15-08000000	顶罩组件 TOP COWLING ASSY	1	
2	F15-00000001	顶罩 TOP COWLING	1	
3	GB/T818-M5x20	十字槽盘头螺钉M5×20 SCREW, PAN HEAD M5×20	2	
4	F15-08000004	挂钩垫 POTHOOK	1	
5	F4-06000006	挂钩垫 UNDERLAY, POTHOOK	1	
6	GB/T845-ST5.5x19	十字槽盘头自攻螺钉 ST5.5x19 SCREW, TAPPING ST5.5x19	4	
7	F4-06000004	橡胶垫片 UNDERLAY, RUBBER	4	
8	F15-08000003	顶罩消音器盖 COVER, TOP COWLING MUFFLE	1	
9	F15-08000002	密封橡胶条 SEAL	1	
10	F15-08000005	锁紧钩 HOOK, LOCKING	1	
11	GB/T97.1-5	平垫圈5 WASHER 5	4	
12	GB/T6170-M5	六角螺母M5 NUT M5	4	

Disassembling and inspection

1. Remove rubber seal.
2. Remove top cowling muffle cover screw and rubber underlay.
3. Remove top cowling muffle cover.
4. Remove locking hook and pothook.
5. Inspect top cowling for crack or damage. Replace if necessary.
6. Inspect rubber seal for crack or damage. Replace if necessary.
7. Inspect top cowling muffle cover for crack or damage. Replace if necessary.
8. Inspect lock hook and pothook for crack, deform or damage. Replace if necessary.

BOTTOM COWLING

Explosive drawing

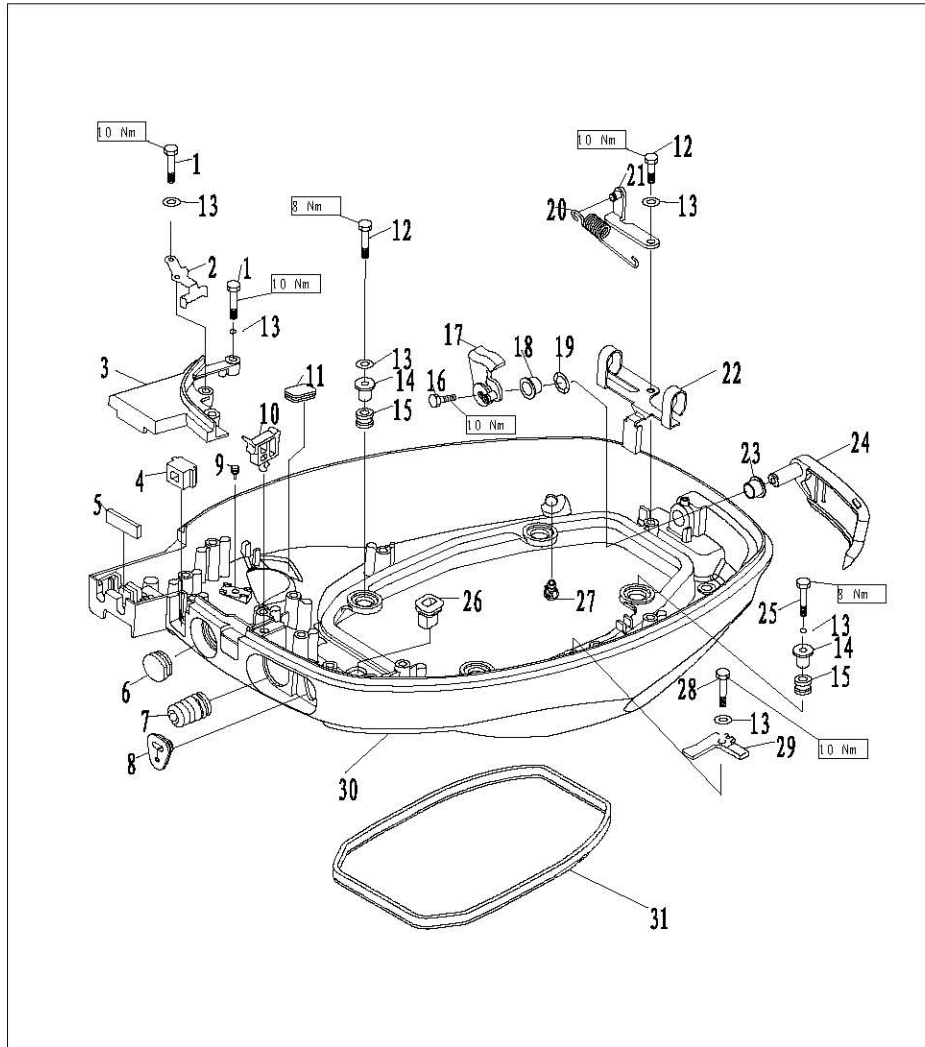

参照号码 SN.	零件编号 PART NO.	零件名称 DESCRIPTION	数量 QTY	备注 REMARKS
1	GB/T5783-M6x30	六角螺栓 M6X30 BOLT HEXAGON M6X30	3	
2	F15-05000019	阻风门导向板 ORIENTED PLATE, CHOKE	1	
3	F15-05000018	底罩小盖板 COVER BOARD, BOTTOM COWLING	1	
4	F15-05010002	阻风门橡胶套 SHEATH, CHOKE	1	
5	F15-05000017	方形橡胶密封条 SEAL, RUBBER	1	
6	F15-05000007	圆形橡胶网头 RUBBER PLUG, CIRCULAR	1	
7	F15-05000006	波纹橡胶套 SHEATH, WAVE	1	
8	F15-01000015	油门钢索护套 JACKET, CABLE	1	
9	F15-05000015	针形橡胶堵头 RUBBER PLUG, NEEDLE	1	
10	F15-05000008	方形线夹A CLAMP A	1	
11	F15-05000003	长方形橡胶网头 RUBBER PLUG, QUADRATE	1	
12	GB/T5783-M6x25	六角螺栓 M6X25 BOLT HEXAGON M6X25	2	

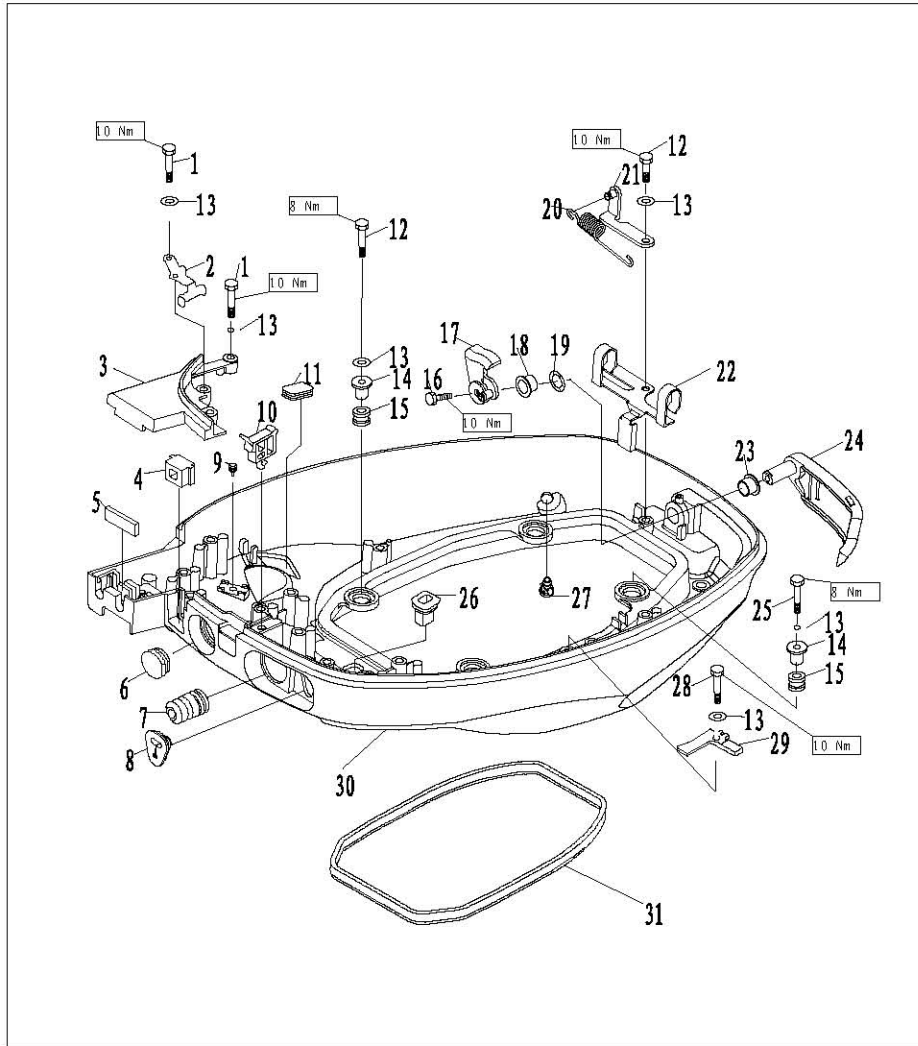

参照号码 SN.	零件编号 PART NO.	零件名称 DESCRIPTION	数量 QTY	备注 REMARKS
13	GB/T91.7-6	平垫圈6 WASHER 6	10	
14	F15-05000005	减震圈衬套 BUSHING, DAMPER	4	
15	F15-05000004	减震圈 DAMPER	4	
16	GB/T5783-M6x12	六角螺栓 M6X12 BOLT, HEXAGON M6X12	1	
17	F15-05030000	顶罩锁紧组件 LOCKING ASSY, TOP COWLING	1	
18	F15-05000036	顶罩锁紧手柄尼龙套B BUSHING B	1	
19	F15-05000023	波形垫圈 WASHER, WAVE	1	
20	F15-05000026	锁紧块拉簧 SPRING, TENSION	1	
21	F15-05000025	拉簧支架组件 BRACKET ASSY, TENSIONAL SPRING	1	
22	F15-05000024	双耳水管卡 CLIP, WATER PIPE	1	
23	F15-05000022	顶罩锁紧手柄尼龙套A BUSHING A	1	
24	F15-05020000	顶罩锁紧手柄组件 LOCKING HANDLE ASSY, TOP COWLING	1	

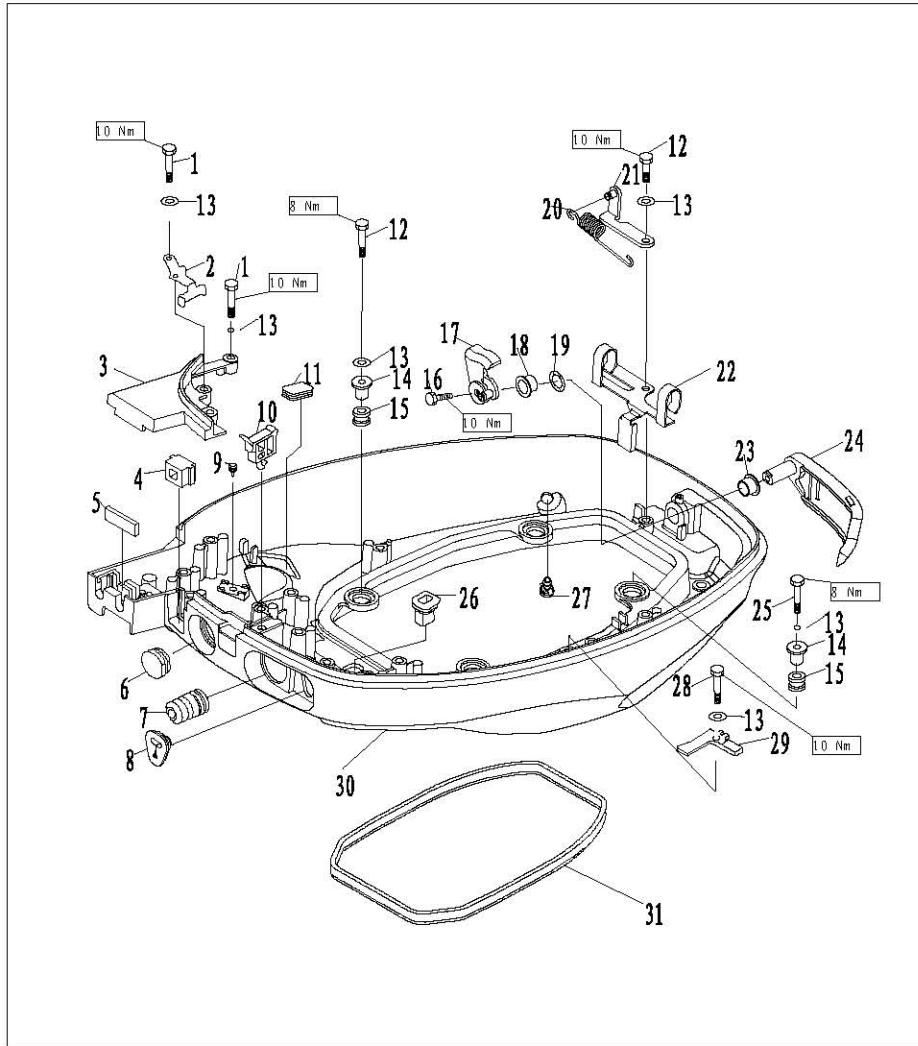

参照号码 SN.	零件编号 PART NO.	零件名称 DESCRIPTION	数量 QTY	备注 REMARKS
25	GB/T5783-M×35	六角螺栓 M6X35	BOLT, HEXAGON M6X35	2
26	F15-05000033	变档连接杆护套	JACKET, LEVER	1
27	F15-05000009	塑料出水嘴	NIPPLE, PLASTIC	1
28	GB/T7583-M6×20	六角螺栓 M6X20	BOLT, HEXAGON M6X20	2
29	F15-05000021	小盖板	COVERING	2
30	F15-05000001	底罩	BOTTOM COWLING	1
31	F15-05000002	底罩密封圈	SEAL, BOTTOM COWLING	1

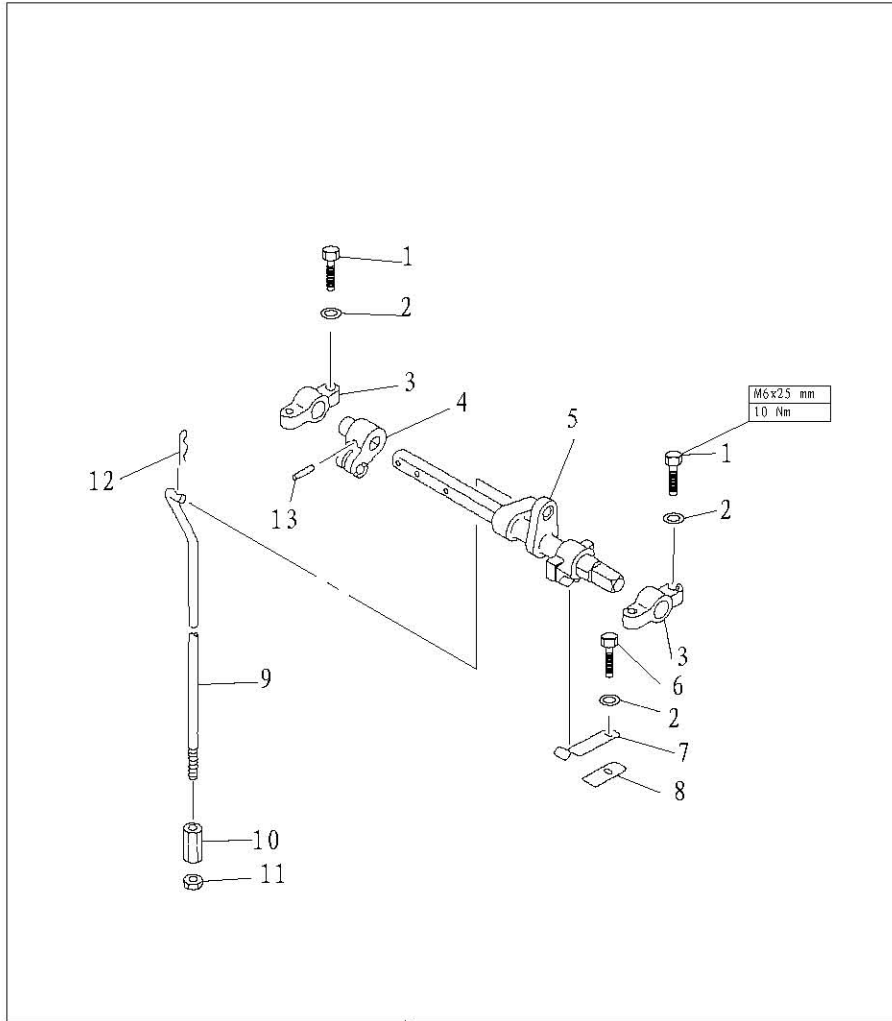

参照号码 SN.	零件编号 PART NO.	零件名称 DESCRIPTION	数量 QTY	备注 REMARKS
1	GB/T5783-M6x25	六角头螺栓M6 × 25	BOLT M6 × 25	4
2	GB/T97.1-6	平垫圈6	WASHER 6	5
3	F15-05040002	变档杆支座	BRACKET, SHIFT ROD	2
4	F15-05040001	制动器摇臂	ROCKER, STOPPER	1
5	F15-05040100	变档杆芯轴组件	LEVER, SHIFT ROD	1
6	GB/T5783-M6x20	六角螺栓M6 × 20	BOLT M6 × 20	1
7	F15-05000031	档位弹簧片	SPRING	1
8	F15-05000032	档位弹簧托片	STOPPER SPRING	1
9	F15-05000034	变档连接杆	SHIFT ROD	1
	F15-05000034S	变档连接杆	SHIFT ROD	1
10	F15-05000035	柱状螺母	COLUMNED NUT	1
11	GB/T41-2000	六角螺母	NUT	1
12	GB/T5783-2000	夹簧	SPRING	1
13	GB/T879.2-3x20	弹性圆柱销 $\phi 3 \times 20$	PIN, SPRING $\phi 3 \times 20$	1

Disassembling and inspection

1. Remove rubber plug, wave sheath and throttle cable jacket.
2. Remove bolts fixing bottom cowling cover board, and remove cover board.
3. Remove top cowling locking handle assembly screws, remove top cowling locking handle and top cowling locking block.
4. Remove top cowling locking handle bush A and top cowling locking handle bush B.
5. Remove wave washer.
6. Remove fixing bolt of shift rod bracket.
7. Remove cotter pin of shift rod.
8. Remove shift rod, spring pin and stopping rocker.
9. Remove spring and stopper spring.
10. Inspect bottom cowling for crack or damage. Replace if necessary.
11. Inspect top cowling locking handle and top cowling lock block for crack or damage. Replace if necessary.
12. Inspect wave washer and locking handle bush for crack or damage. Replace if necessary.
13. Inspect shift rod bracket and stopping rocker for crack or damage. Replace if necessary.
14. Inspect spring and stopper spring for crack, crank or damage. Replace if necessary.

STEERING HANDLE

Explosive drawing

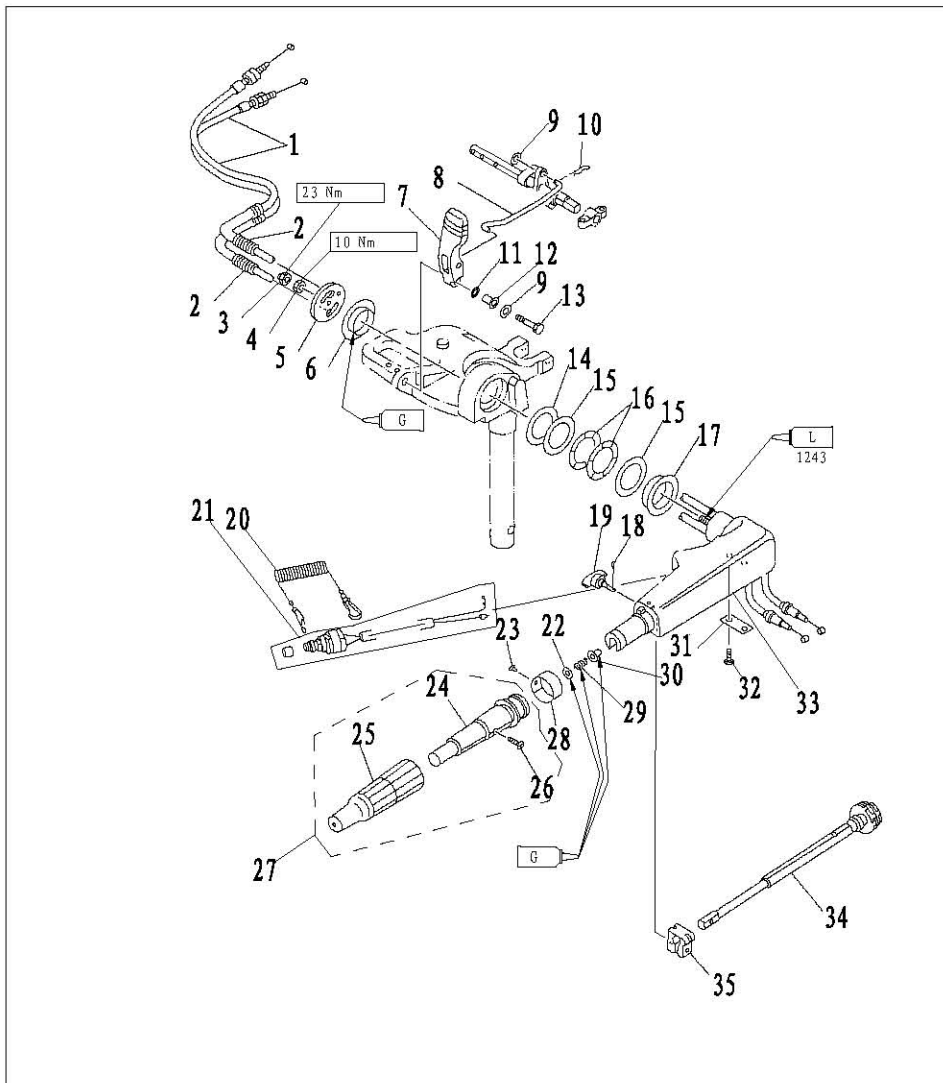

参照号码 SN.	零件编号 PART NO.	零件名称 DESCRIPTION	数量 QTY	备注 REMARKS
1	F15-01030004	油门钢索组件 THROTTLE CABLE ASSY	2	
2	F15-01000014	波纹塑管 TUBE , WAVE PLASTIC	2	
3	GB/T889-M10x1.25	六角锁紧螺母M10×1.25 LOCKNUT M10×1.25	4	
4	GB/T6171-M10x1.25	六角螺母M10×1.25 NUT M10×1.25	1	
5	F15-01000013	手柄定位板 PLATE , HANDLE ORIENTATION	1	
6	F15-01000011	手柄衬套(低) WASHER , HANDLE (LOW)	1	
7	F15-00000007	变档手柄 HANDLE , GEAR SHIFT	1	
8	F15-00000011	变档连杆 LINK , SHIFT ROD	1	
9	GB/T97.1-6	平垫圈6 WASHER , PLAIN 6	2	
10	F15-00000012	夹簧 SPRING , CLAMP	1	
11	F15-00000009	波形垫圈 WASHER , WAVE	2	
12	F15-00000008	凸缘垫管 TUBE , FLANGE	2	

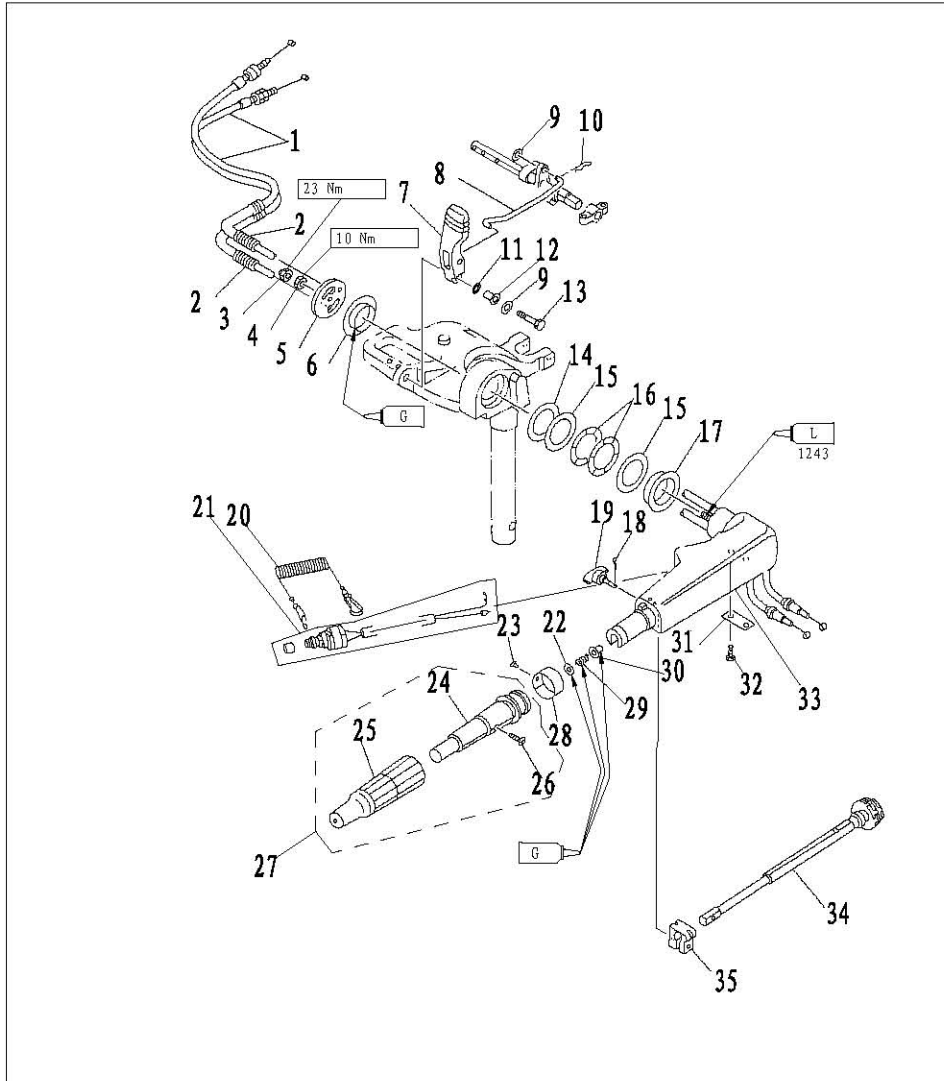

参照号码 SN.	零件编号 PART NO.	零件名称 DESCRIPTION	数量 QTY	备注 REMARKS
13	GB/T5783-M6x30	六角头螺栓M6×30 HEXAGON BOLT M6×30	1	
14	F15-01000012	衬套尼龙圈 WASHER , NYLON	1	
15	F15-01000008	衬套垫圈 WASHER	2	
16	F15-01000009	衬套波形垫圈 WASHER , WAVE	2	
17	F15-01000007	手柄衬套(高) BUSH , HANDLE	1	
18	GB/T91-1.6x12	开口销Φ1.6×12 PIN ,COTTER Φ1.6×1	1	
19	F15-01030200	阻力调整旋钮组件 BOLT	1	
20	F4-01090401	引擎停止安全索 STOPER ,HANG ROPE ASSY	1	
21	F4-01090400	急停开关组件 ENGINE STOP SWITCH ASSY	1	
22	GB/T848-10	小垫圈10 SMALL WASHER 10	1	
23	GB/T827-2x5	标牌铆钉2×5 RIVBT ,SEMICIRCLE 2×5	1	
24	F4-01090301	操舵手柄塑胶套 GRIP ,STEBRING HANDLE	1	

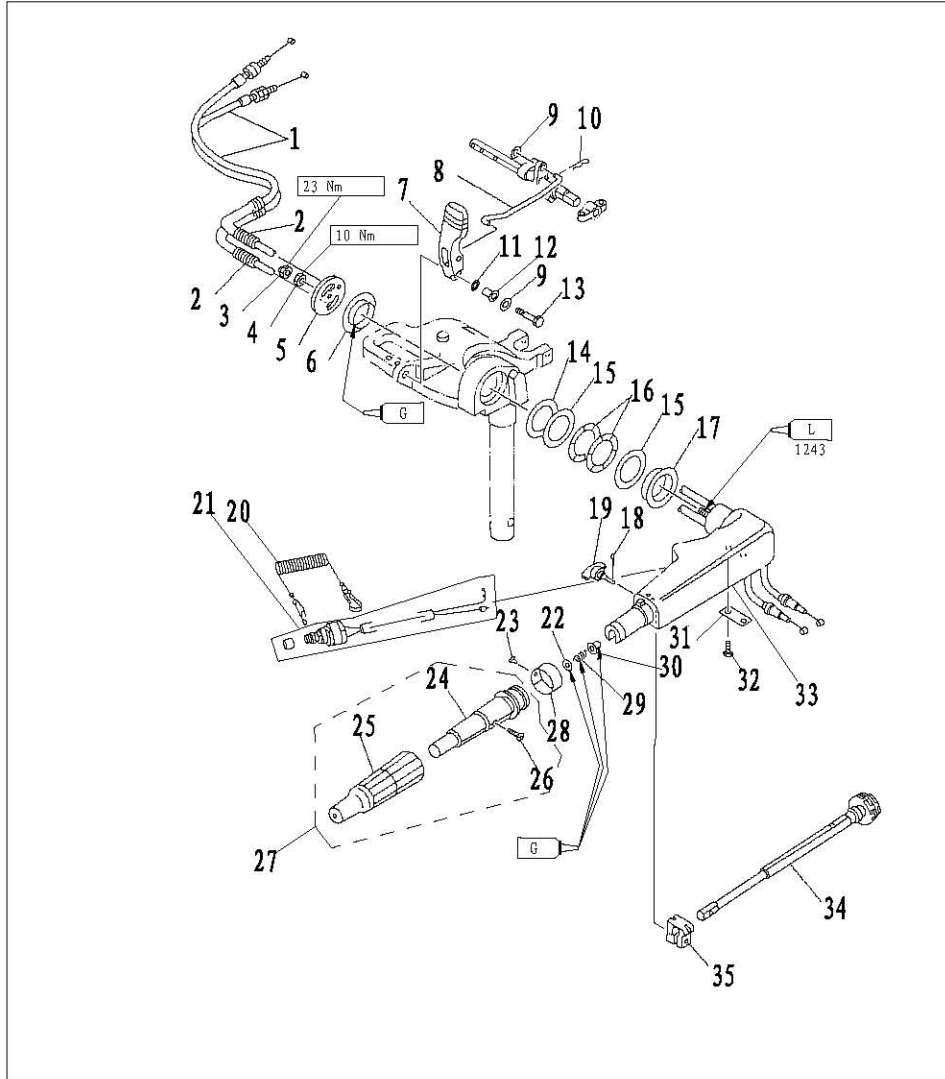

参照号码 SN.	零件编号 PART NO.	零件名称 DESCRIPTION	数量 QTY	备注 REMARKS
25	F4-01090302	操纵手柄橡胶套 RUBBER, HANDLE	1	
26	GB/T820-M5x25	十字槽半沉头螺钉M5×25 SCREW M5×25	1	
27	F4-01090300	操纵手柄橡胶套组件 STEERING HANDLE ASSY	1	
28	F4-01090303	油门标志牌 INDICATOR THROTTLE	1	
29	F4-01090007	压缩弹簧 SPRING, COMPRESSION	1	
30	F4-01090006	衬套 BUSH	1	
31	F15-01030005	节气门固定板 STAY	1	
32	GB/T5783-M6x20	六角头螺栓M6×20 HEXAGON BOLT M6×20	2	
33	F15-01030001	操纵手柄 HANDLE STEERING	1	
34	F15-01030100	节气门杆组件 LEVER, THROTTLE ASSY	1	
35	F4-01090003	操纵手柄握把摩擦块 FRICTION	1	

Disassembling and inspection

1. Remove shift handle.
2. Remove steering handle cover.
3. Remove handle bush, bush washer and wave washer.
4. Remove cotter pin and friction adjusting bolt.
5. Remove throttle handle.
6. Remove throttle cable.
7. Remove throttle lever stay and throttle lever.
8. Remove engine stop switch.
9. Inspect shift handle for crack or damage. Replace if necessary.
10. Inspect steering handle for crack or damage. Replace if necessary.
11. Inspect bush, bush washer and wave washer for crack or damage. Replace if necessary.

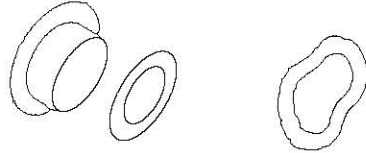

12. Inspect throttle cable for wear or crack. Replace if necessary.
13. Inspect the conduction of engine stop switch. Replace if out of specification.

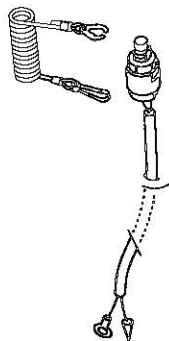

Remove locking plate:	Conducting
Install locking plate:	Not conducting
Push stop switch button:	Conducting

BRACKET

Explosive drawing

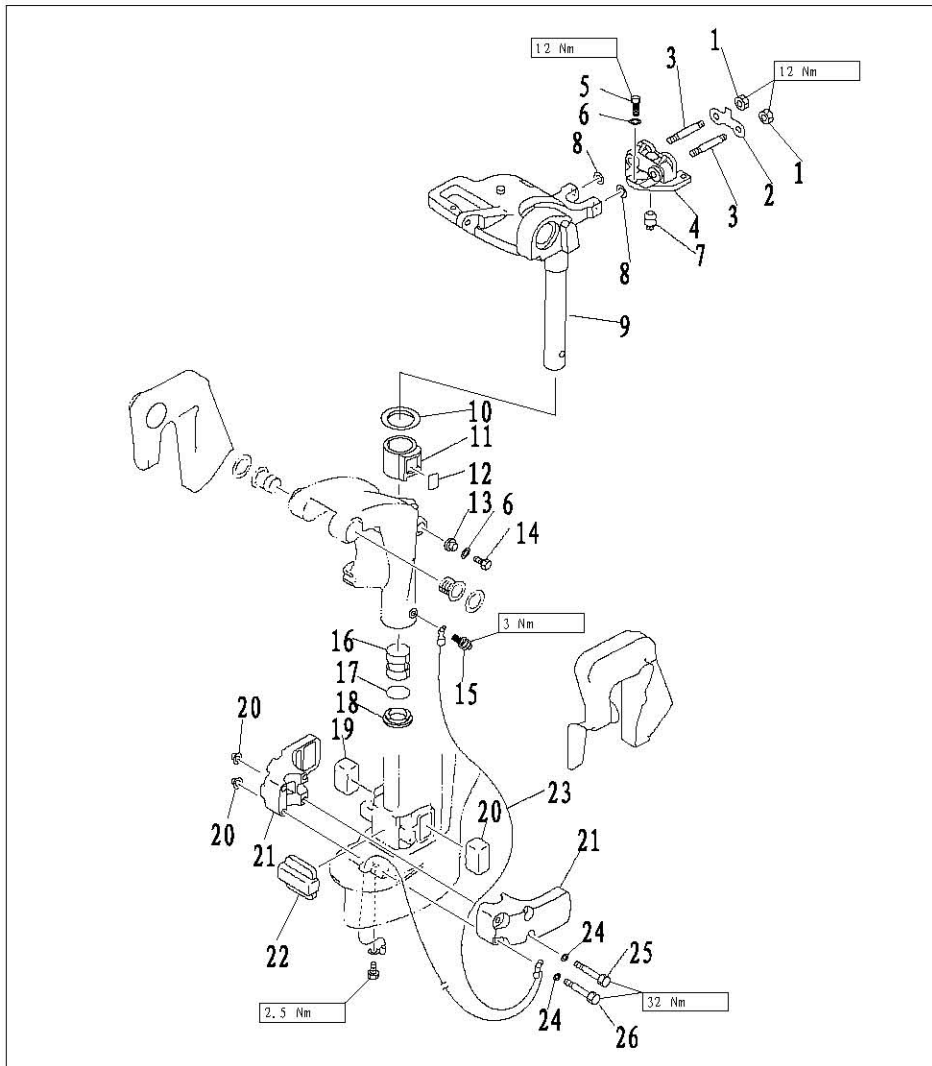

参照号码 SN.	零件编号 PART NO.	零件名称 DESCRIPTION	数量 QTY	备注 REMARKS
1	GB/T6170-M8	六角螺母M8 NUT M8	2	
2	F15-00000004	垫板 PLATE	1	
3	GB/T900-M8x50	双头螺栓M8×50 BOLT, DOUBLE HEAD M8×50	2	
4	F15-02010000	双孔减震器组件 DOUBLE HOLE SHOCK ABSORBER ASSY	1	
5	GB/T5783-M6x25	六角螺栓M6×25 BOLT M6×25	3	
6	GB/T97.1-6	平垫圈6 WASHER 6	3	
7	F15-02010003	水管密封圈上 SEAL, WATER TUBE	1	
8	F15-00000016	特大垫圈 LARGE WASHER	2	
9	F15-01020001	操舵托架 BRACKET, HELM	1	L
	F15-01020001S	操舵托架 BRACKET, HELM	1	S
10	F15-01000003	旋转支架上垫圈 WASHER, ABOVE	1	
11	F15-01000001	旋转支架上衬套 BUSH, ABOVE	1	
12	F15-01000002	上衬套锁紧块 PLATE, LOCK	1	

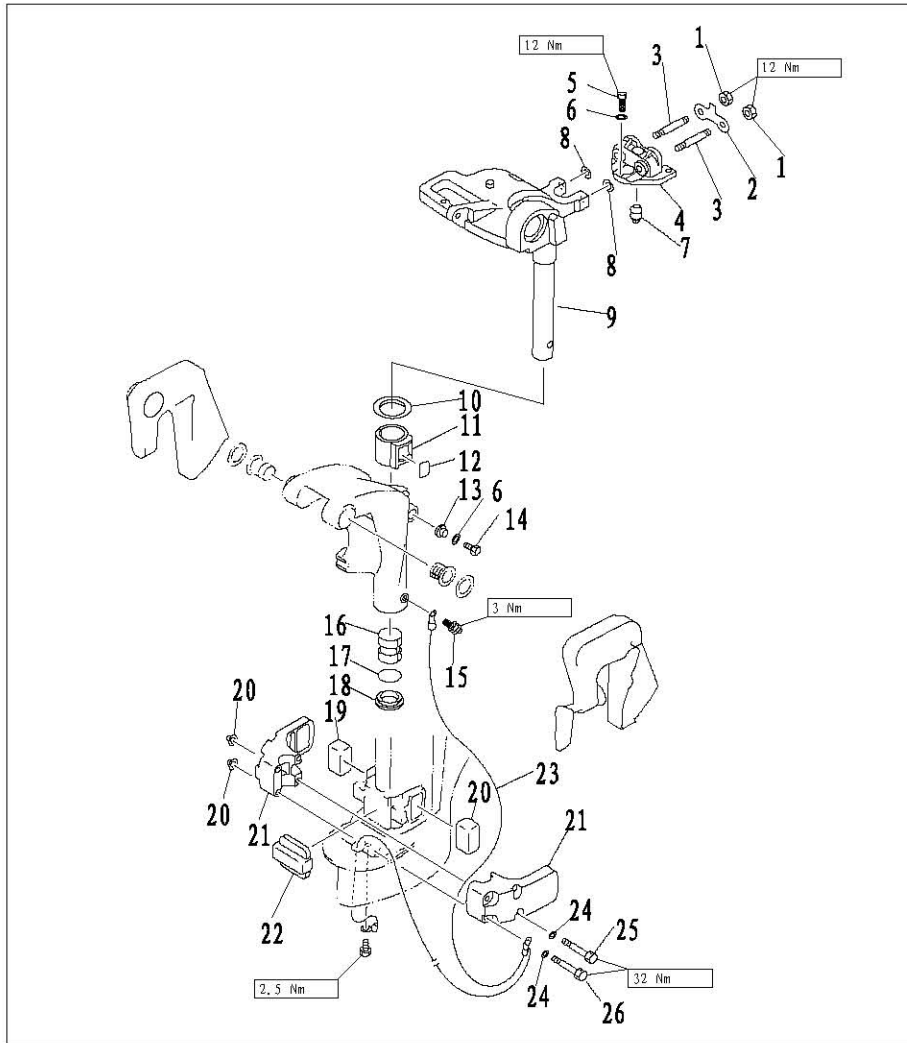

参照号码 SN.	零件编号 PART NO.	零件名称 DESCRIPTION	数量 QTY	备注 REMARKS
13	F15-01010303	锁紧螺栓密封圈 SEAL, LOCK BOLT	1	
14	GB/T5783-M6x20	六角螺栓M6×20 BOLT M6×20	1	
15	JB/T 7940.1-M6	直通式压注油杯M6 OILER	1	
16	F15-01000004	旋转支架下衬套 BUSH, BELOW	1	
17	GB/T3452.1-30x3.55	下衬套O形圈30×3.55 O-RING 30×3.55	1	
18	F15-01000006	旋转支架下垫圈 WASHER, BELOW	1	
19	F15-00000002	左右减震块 MOUNT DAMPER, LEFT AND RIGHT	2	
20	GB/T6177-M8	六角法兰面螺母M8 NUT M8	4	
21	F15-00000001	减震块外壳 SHELL, MOUNT DAMPER	2	
22	F15-00000003	前减震块 MOUNT DAMPER, FRONT	1	
23	F15-02000003	接地钢索B TIGHTWIRE, EARTHING	1	
24	GB/T97.1-8	平垫圈8 WASHER 8	4	
25	GB/T5782-M8x105	六角螺栓M8×105 BOLT M8×105	2	
26	GB/T5782-M8x85	六角螺栓M8×85 BOLT M8×85	2	

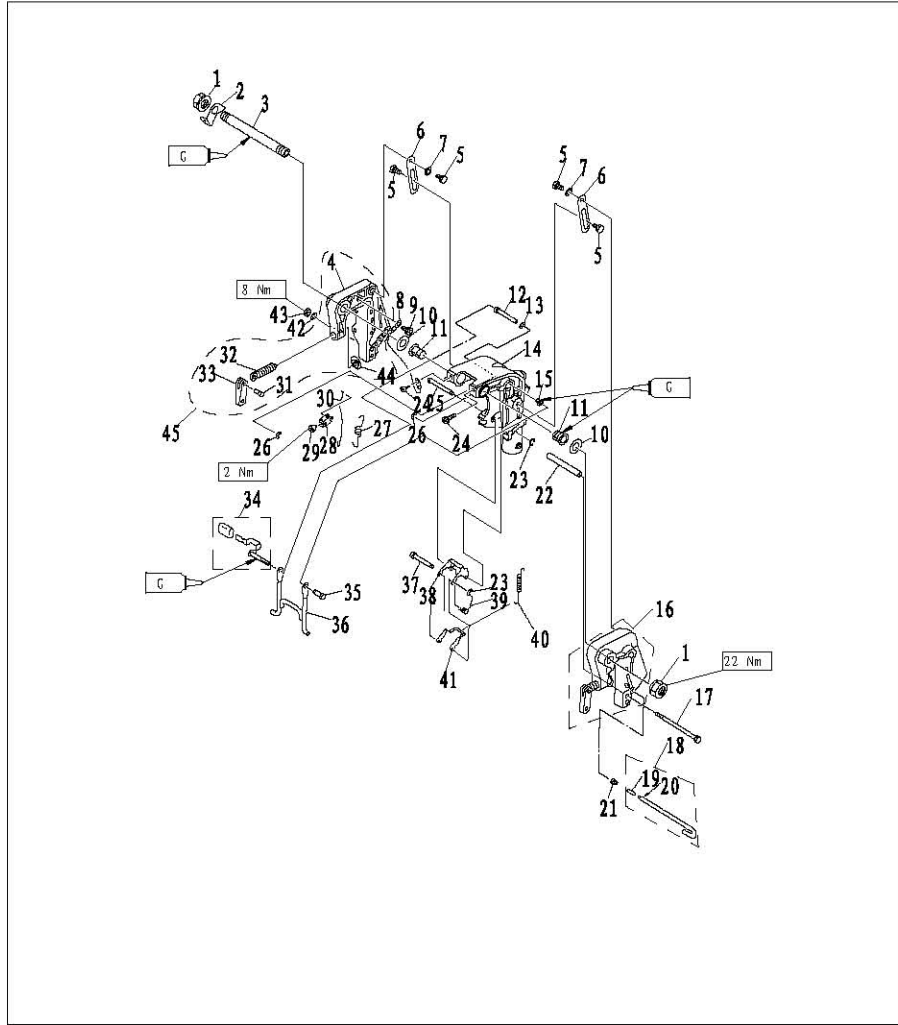

参照号码 SN.	零件编号 PART NO.	零件名称 DESCRIPTION	数量 QTY	备注 REMARKS
1	F15-01010007	托架夹紧螺母	2	
2	F15-01010003	双孔固定板	1	
3	F15-01010001	夹紧托架双头螺管	1	
4	F15-01010201	右夹紧托架	1	
5	F15-01010103	扁六角轴位螺钉	4	
6	F15-01010105	倾斜制动板	2	
7	F15-01010104	波形垫圈	1	
8	F15-01010202	接地钢索A	1	
9	GB/T818-M6x8	十字槽盘头螺钉M6×8	1	
10	F15-01010002	螺管尼龙垫圈	2	
11	F15-01010302	旋转支架螺管衬套	2	
12	F15-01010308	角度支撑定位轴套	1	
13	F15-01010309	角度支撑尼龙片	1	
14	F15-01010301	旋转支架	1	L
	F15-01010301S	旋转支架	1	S

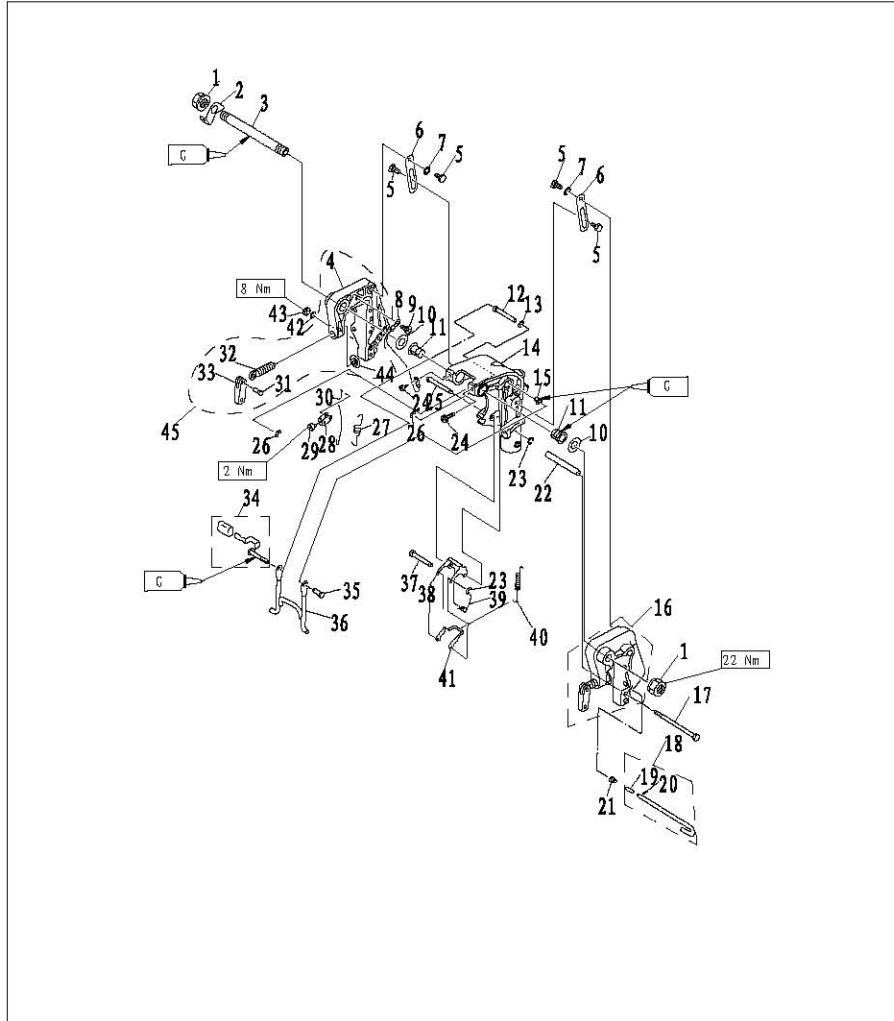

参照号码 SN.	零件编号 PART NO.	零件名称 DESCRIPTION	数量 QTY	备注 REMARKS
15	F15-01010311	角度支撑尼龙衬套 BUSH, NYLON	1	
16	F15-01010100	左夹紧托架组件 LEFT BRACKET ASSY	1	
17	GB/T5782-M6x145	六角螺栓M6 × 145 BOLT M6 × 145	1	
18	F15-01010400	角度限位杆组件 LIMITATIVE ROD ASSY	1	
19	F4-01050003	防脱落支脚 NOG, PREVENTED UNLOCK	1	
20	GB/T879.1-3x8	弹性圆柱销3 × 8 PIN, SPRING 3 × 8	1	
21	F15-01010402	锥形弹簧 CONICAL SPRING	1	
22	F15-01010006	螺栓套管 TUBE, BOLT	1	
23	GB/T896-4	开口档圈4 CIRCLIP 4	2	
24	GB/T818-M8x10	十字槽盘头螺钉M8 × 10 SCREW, PAN HEAD M8 × 10	2	
25	F15-01010316	角度锁紧架长轴 LONG SHAFT, LOCK ANGLE	1	
26	GB/T896-5	开口档圈5 CIRCLIP 5	2	
27	F15-01010304	角度支撑架拉簧 SPRING, TENSION	1	
28	F15-01010306	角度定位件 LEVER, ANGLE ORIENTATION	1	
29	GB/T818-M5x6	十字槽盘头螺钉M5 × 6 SCREW, PAN HEAD M5 × 6	1	

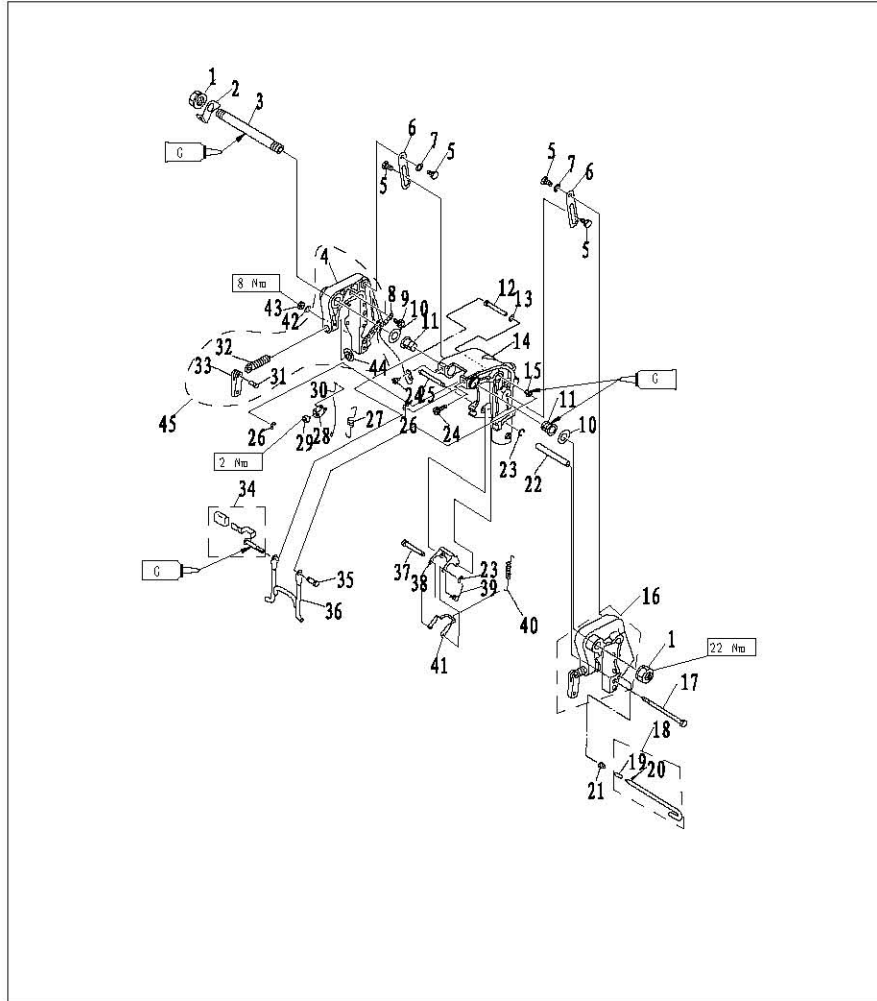

参照号码 SN.	零件编号 PART NO.	零件名称 DESCRIPTION	数量 QTY	备注 REMARKS
30	F15-01010307	锁紧支架连杆 ROD, TILT LOCK	1	
31	F4-01010005	舰板夹紧手柄铆钉 RIVET, CLAMP HANDLE	2	
32	F15-01010102	舰板夹紧螺杆 SCREW, CLAMP	2	
33	F4-01010004	角度锁紧手柄组件 CLAMP SHIPBOARD HANDLE	2	
34	F15-01010305	舰板夹紧手柄 TILT CLAMP HANDLE ASSY	1	
35	F15-01010312	角度支撑定位轴 SHAFT, STOPPER	1	
36	F15-01010313	角度支撑组件 SUPPORT ASSY	1	
37	F15-01010317-3	角度锁紧短轴 SHORT SHAFT, LOCK ANGLE	1	
38	F15-01010317-2	角度锁紧外架 BRACKET, LOCK ANGLE	1	
39	F15-01010315	角度锁紧架扭簧 SPRING, TORSION	1	
40	F15-01010314	角度锁紧架拉簧 SPRING, TENSION	1	
41	F15-01010317-1	角度锁紧内架 INNER BRACKET	1	
42	GB/T848-6	小垫圈6 WASHER 6	1	
43	GB/T6170-M6	六角螺母M6 NUT M6	1	
44	F4-01010003	舰板夹紧圆盘 CLAMP PLATE	2	
45	F15-01010200	右夹紧托架组件 RIGHT BRACKET ASSY	1	

Disassembling and inspection

1. Remove limitative rod and bolt (M6X145).
2. Remove nut and bolt of tilt stopper plate, and remove the tilt stopper plate.

3. Remove clamp bracket nut, two hole plate, and double head bolt of clamp bracket.
4. Remove clamp bracket.
5. Remove rotary bracket.
6. Remove lock angle handle and tilt lock rod. Remove tension spring and angle orientation lever.
7. Remove orientation bushing and nylon bush.
8. Remove lock angle long shaft and short shaft.
9. Remove lock angle bracket, torsion spring, tension spring and inner bracket.
10. Inspect rotary bracket and clamp bracket for damage or crack. Replace if necessary.
11. Inspect bush and gasket for damage or crack. Replace if necessary.
12. Inspect lock angle bracket and support bracket for deform. Replace if necessary.

UPPER UNIT

Explosive drawing

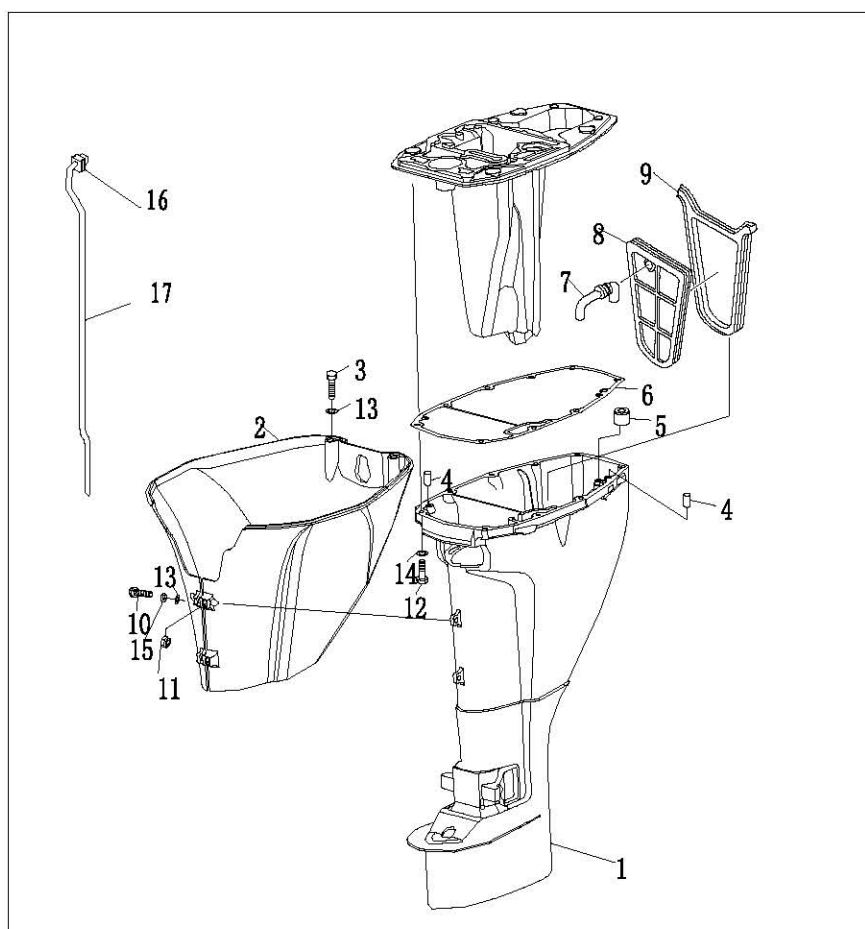

参照号码	零件编号	零件名称	数量	备注	
SN.	PART NO.	DESCRIPTION	QTY	REMARKS	
1	F15-02000001	水上装置壳体	UPPER CASING	1	L
	F15-02000001S	水上装置壳体	UPPER CASING	1	S
2	F15-00000015	水上装置罩壳	MANTLE, UPPER CASING	1	
3	GB/T5783-M6x16	六角螺栓 M6X16	HEXAGON BOLT M6X16	2	
4	F15-00000006	定位销	PIN, DOWEL	2	
5	F15-02000007	鼓形密封圈	SEAL	1	
6	F15-00000005	油底壳密封垫	GASKET	1	
7	F15-03000002	排气橡胶管	RUBBER PIPE, EXHAUST	1	
8	F15-03000001	排气隔板	CLAPBOARD, EXHAUST	1	
9	F15-03000003	隔板密封圈	SEAL, CLAPBOARD	1	
10	GB/T818-M6x25	十字槽盘头螺钉 M6X25	BOLT	2	
11	GB/T41-2000	六角螺母	NUT, HEXAGON	2	
12	GB/T5783-M8x45	六角螺栓 M8X45	BOLT, HEXAGON M8X45	6	
13	GB/T97.1-6	平垫圈 6	WASHER 6	4	
14	GB/T97.1-8	平垫圈 8	WASHER 8	6	
15	GB/T93-6	弹性垫圈 6	WASHER, SPRING	2	
16	F15-02000006	水管方形密封圈	QUADRATE SEAL, WATER PIPE	1	
17	F15-02000005	水管	TUBE, WATER	1	L
	F15-02000005S	水管	TUBE, WATER	1	S

Disassembling and inspection

1. Remove the oil sump.
2. Remove the oil seal and abnormality seal.
3. Remove the exhaust pipe, oil drain bolt, oil drain jacket and exhaust pipe seal.
4. Remove double hole shock absorber assy, water pipe quadrate seal and water pipe.
5. Check the upper casing for crack or wear. Replace if necessary.
6. Check water pipe for deform or erosion. Replace if necessary.
7. Check exhaust clapboard for damage, wear or crack. Replace if necessary.

LOWER UNIT WATER PUMP ASSEMBLY

Explosive drawing

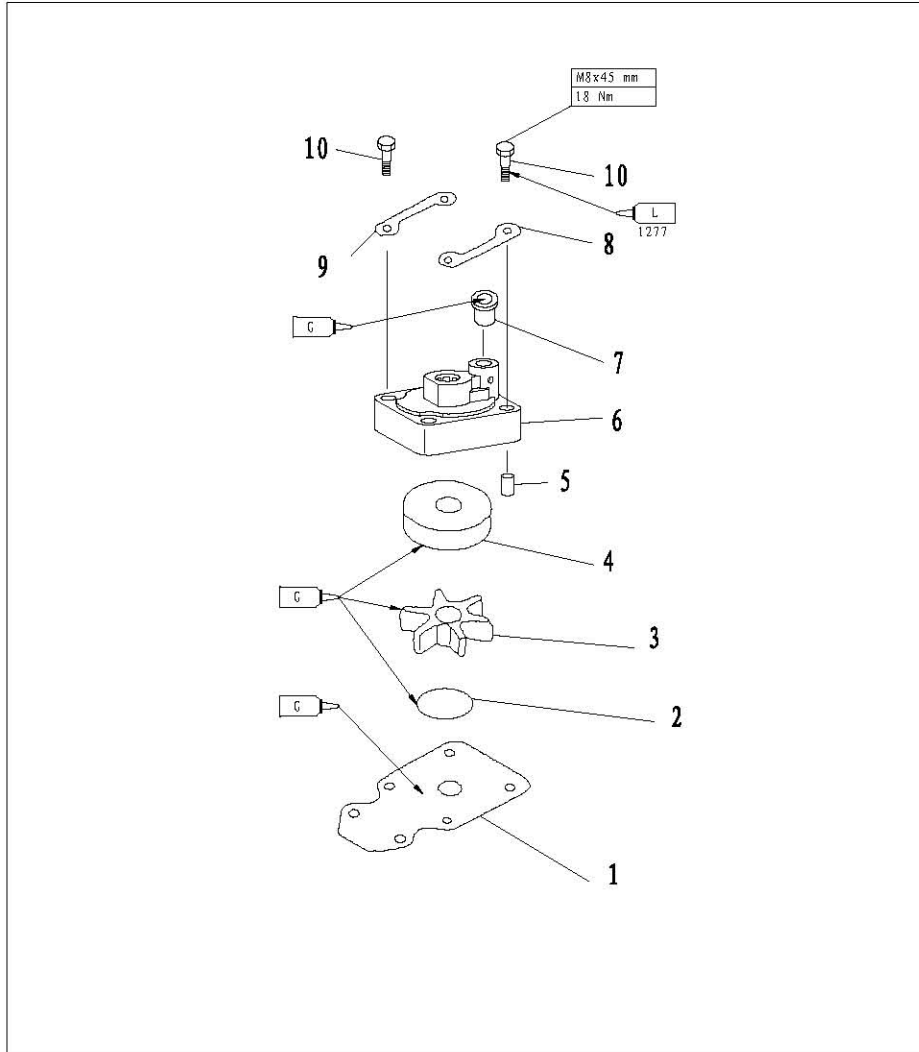

参照号码 SN.	零件编号 PART NO.	零件名称 DESCRIPTION	数量 QTY	备注 REMARKS
1	F15-0600007	外挡板 OUTER PLATE	1	
2	JASO F404-96	水泵壳O型密封圈31-45 O-RING 31-45	1	
3	F15-06050000	水泵叶轮组件 IMPELLER	1	
4	F15-06060002	水泵内壳 INNER SHELL, WATER PUMP	1	
5	F15-00000013	定位销φ4X12 PIN, DOWEL φ4X12	2	
6	F15-06060001	水泵壳体 WATER PUMP HOUSING	1	
7	F15-02000004	水管密封圈上 UPPER SEAL, WATER PIPE	1	
8	F15-06060004	泵壳水管密封圈 SEAL	1	
9	F15-06000014	泵壳固定板 FIXED PLATE, WATER PUMP	2	
10	GB/T5783-M8x45	六角螺栓 M8X45 BOLT, HEXAGON M8X45	4	

Disassembling and inspection

1. Remove water pump fixed plate.
2. Remove water pump housing.
3. Remove impeller and water pump inner shell.
4. Remove woodruff key and outer plate.
5. Check water pump housing and outer plate for crack, crank or damage. Replace if necessary.
6. Check inner water pump inner shell and impeller for crack, deform, burn or damage. Replace if necessary.

LOWER UNIT

Explosive drawing

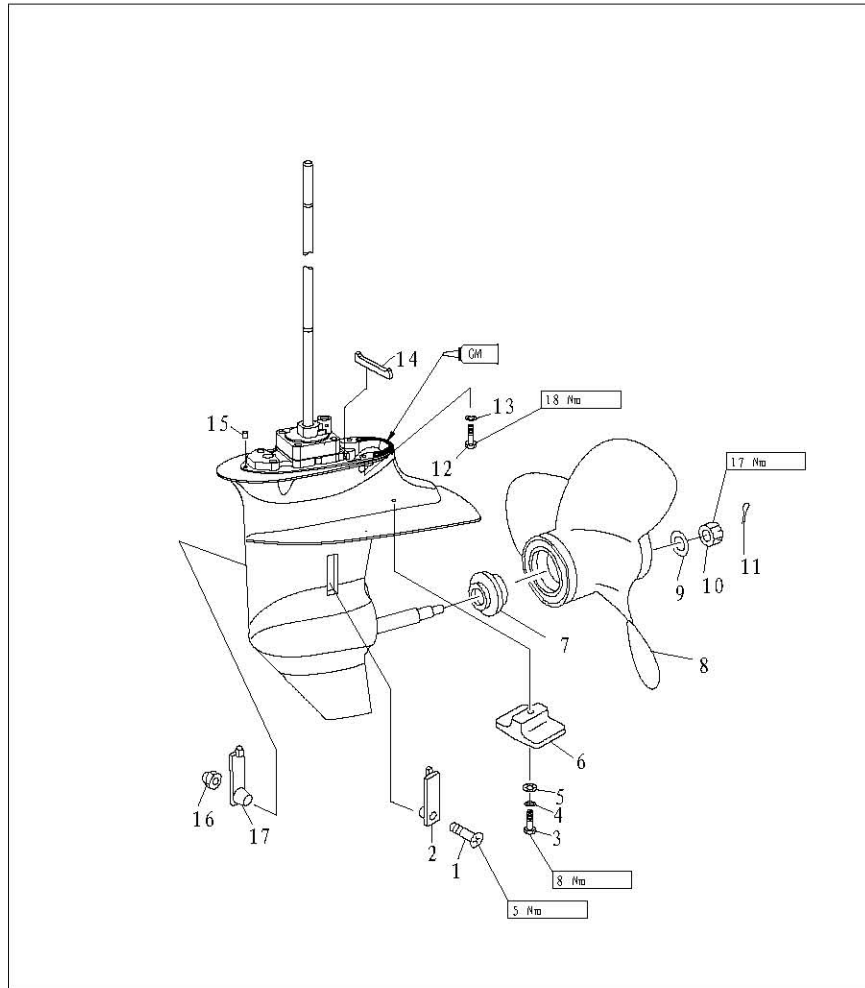

参照号码 SN.	零件编号 PART NO.	零件名称 DESCRIPTION	数量 QTY	备注 REMARKS
1	GB/T820-M5x25	十字槽半沉头螺钉M5x25	1	SCREW M5X25
2	F15-06000003	进水口 B	1	WATER INLET B
3	GB/T5783-M6x30	六角螺栓 M6X30	1	BOLT, HEXAGON M6X30
4	GB/T97.1-6	平垫圈 6	1	WASHER 6
5	GB/T861.1-6	内齿锁紧垫圈 6	1	WASHER, LOCKING 6
6	F15-06000004	水下阳极	1	ANODE
7	F15-06000015	螺旋桨垫块	1	CUSHION, PROPELLER
8	F15-06090000	螺旋桨组件	1	PROPELLER ASSY
9	GB/T96-10	大垫圈 10	1	WASHER 10
10	F15-06000016	开槽六角螺母	1	NUT, HEXAGON
11	GB/T91-2.5x20	开口销 2.5X20	1	PIN, COTTER 2.5X20
12	GB/T5783-M8x30	六角螺栓 M8X30	4	BOLT, HEXAGON M8X30
13	GB/T97.1-8	平垫圈 8	4	WASHER 8
14	F15-06020005	橡胶密封条	1	SEAL, RUBBER
15	F15-00000013	定位销 $\phi 4 \times 12$	2	PIN, DOWEL $\phi 4 \times 12$
16	GB/T6182-M5	非金属嵌件六角锁紧螺母M5	1	NUT, LOCKING M5
17	F15-06000002	进水口 A	1	WATER INLET A

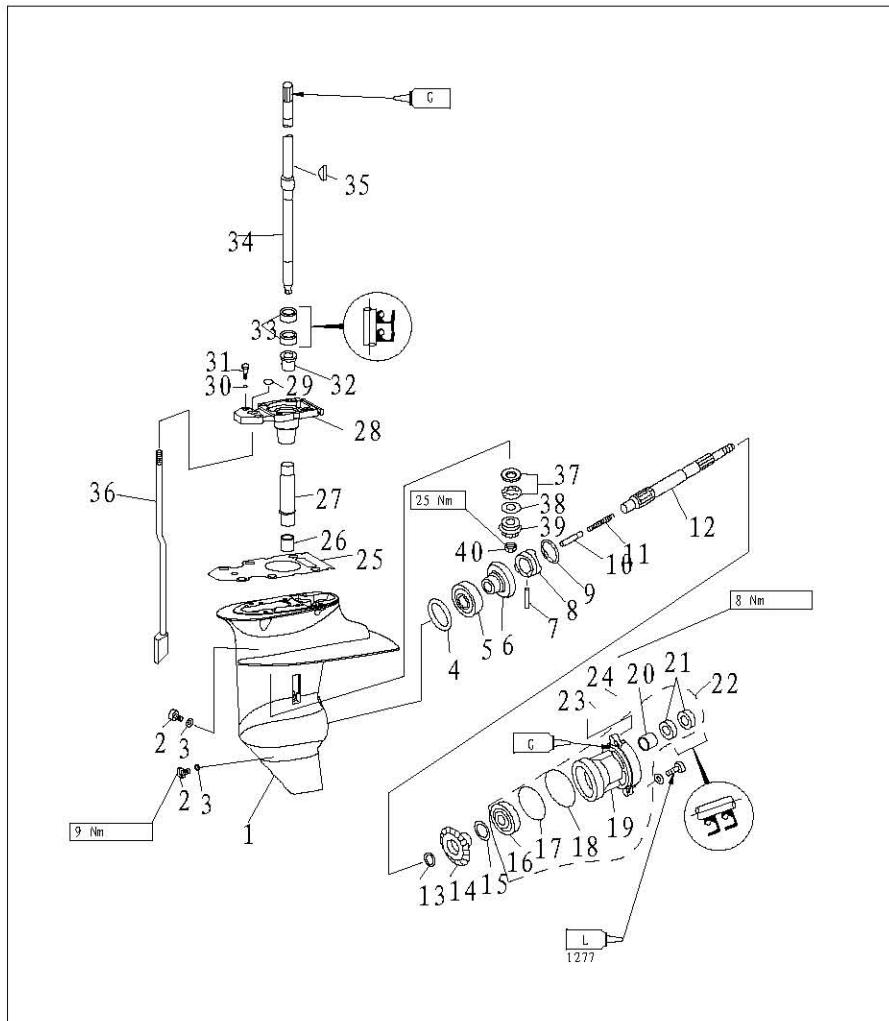

参照号码	零件编号	零件名称	数量	备注
SN.	PART NO.	DESCRIPTION	QTY	REMARKS
1	F15-06000001	水下装置壳体 LOWER CASING	1	
2	F4-03000023	注油孔螺塞 PLUG, OIL HOSE	2	
3	F4-03000024	注油孔螺塞垫圈 GASKET	2	
4	F15-06000010-1	正档齿轮填隙片 (t: 0.10毫米) SHIM (t: 0.10MM)		
	F15-06000010-2	正档齿轮填隙片 (t: 0.12毫米) SHIM (t: 0.12MM)		
	F15-06000010-3	正档齿轮填隙片 (t: 0.15毫米) SHIM (t: 0.15MM)		
	F15-06000010-4	正档齿轮填隙片 (t: 0.18毫米) SHIM (t: 0.18MM)		
	F15-06000010-5	正档齿轮填隙片 (t: 0.30毫米) SHIM (t: 0.30MM)		
	F15-06000010-6	正档齿轮填隙片 (t: 0.40毫米) SHIM (t: 0.40MM)		
	F15-06000010-7	正档齿轮填隙片 (t: 0.50毫米) SHIM (t: 0.50MM)		
5	NTN 4T-30205 1L	圆锥滚子轴承 BEARING	1	
6	F15-06010000	正档齿轮组件 GEAR, FORWARD	1	
7	F15-06070004	离合器销 PIN, CLUTCH	1	
8	F15-06070003	爪形离合器 CLUTCH, DOG	1	
9	F15-06070005	离合器环 RING, CLUTCH	1	

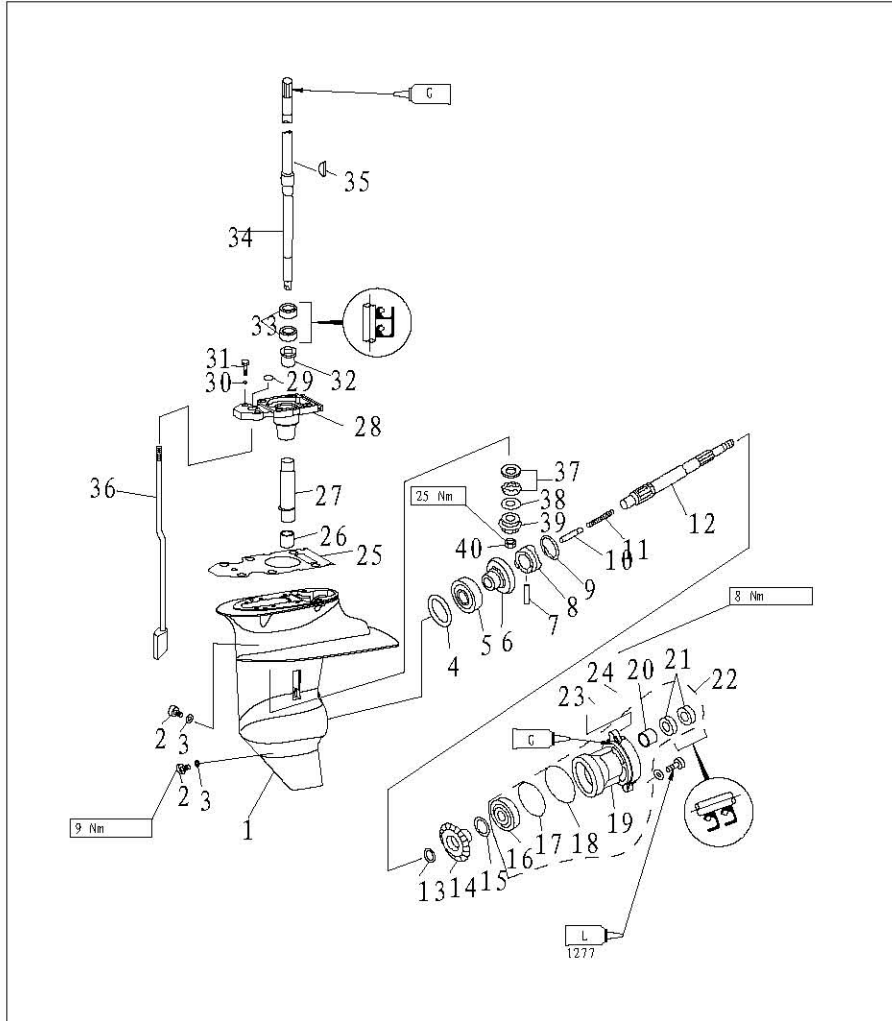

参照号码 SN.	零件编号 PART NO.	零件名称 DESCRIPTION	数量 QTY	备注 REMARKS
10	F15-06070006	变档柱塞 PLUNGER, SHIFT	1	
11	F15-06070002	离合器弹簧 SPRING, CLUTCH	1	
12	F15-06070001	螺旋桨轴 SHAFT, PROPELLER	1	
13	F15-06070007	倒档齿轮垫圈 WASHER, REVERSE GEAR	1	
14	F15-06080005	倒档齿轮 GEAR, REVERSE	1	
15	F15-06080006-1	倒档齿轮填隙片(t: 0.10毫米) SHIM (t: 0.10MM)		
	F15-06080006-2	倒档齿轮填隙片(t: 0.20毫米) SHIM (t: 0.20MM)		
	F15-06080006-3	倒档齿轮填隙片(t: 0.30毫米) SHIM (t: 0.30MM)		
	F15-06080006-4	倒档齿轮填隙片(t: 0.40毫米) SHIM (t: 0.40MM)		
	F15-06080006-5	倒档齿轮填隙片(t: 0.50毫米) SHIM (t: 0.50MM)		
16	GB/T276-6005	深沟球轴承 6005 BEARING 6005	1	
17	F15-06080002	水下壳体盖O型圈A O-RING A, COVER	1	
18	F15-06080003	水下壳体盖O型圈B O-RING B, COVER	1	
19	F15-06080001	水下装置壳体盖 COVER, LOWER CASING	1	
20	KOYO 17BM2312	滚针轴承 17BM2312 BEARING 17BM2312	1	

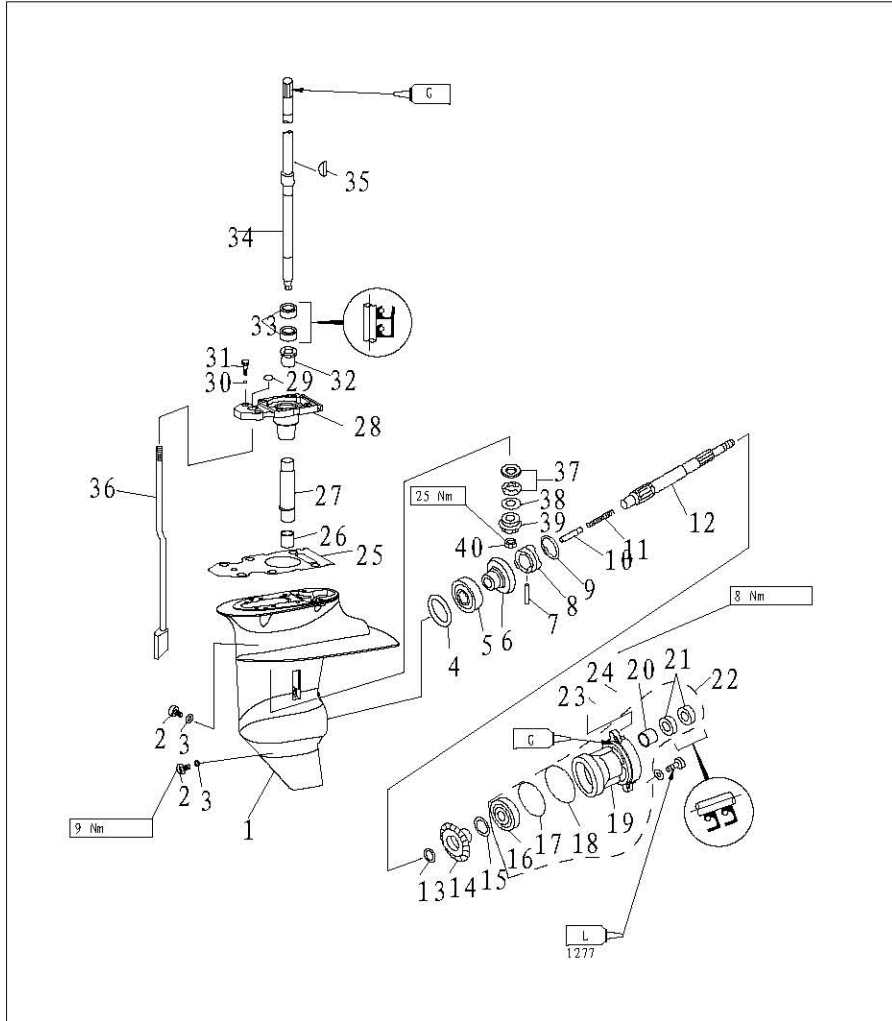

参照号码 SN.	零件编号 PART NO.	零件名称 DESCRIPTION	数量 QTY	备注 REMARKS
21	F15-06080004	螺旋泵轴油封17X30X6 (单唇) OIL SEAL	2	
22	F15-06080000	水上装置壳体盖组件 COVER ASSY, LOWER CASING	1	
23	GB/T97.1-6	平垫圈 6 WASHER 6	2	
24	GB/T5783-M6x20	六角螺栓 M6X20 BOLT, HEXAGON M6X20	2	
25	F15-06000005	驱动轴座密封垫 WASHER	1	
26	NSK F1420	滚针轴承 F1420 BEARING F1420	1	
27	F15-06000006	长尼龙套管 BUSHING, NYLON	1	
28	F15-06020001	驱动轴座 BASE, DRIVE SHAFT	1	
29	F15-06020004	O型圈 O-RING	1	
30	GB/T97.1-8	平垫圈 8 WASHER 8	2	
31	GB/T5783-M8x25	六角螺栓 M8X25 BOLT, HEXAGON M8X25	2	
32	F15-06020002	带挡边筒形轴承 BEARING	1	
33	F15-06020003	驱动轴油封 20X30X6 (单唇) OIL SEAL, DRIVE SHAFT 20X30X6	2	
34	F15-06040000	驱动轴组件 DRIVE SHAFT ASSY	1	L
	F15-06040000S	驱动轴组件 DRIVE SHAFT ASSY	1	S

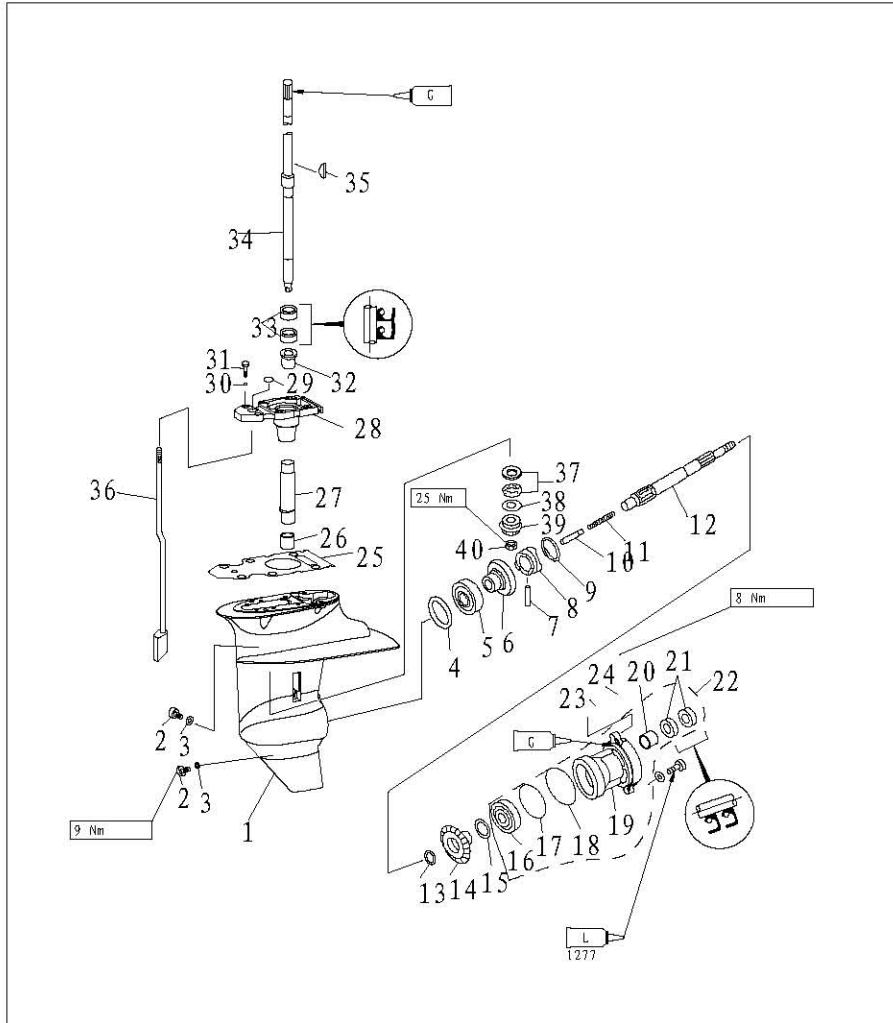

参照号码 SN.	零件编号 PART NO.	零件名称 DESCRIPTION	数量 QTY	备注 REMARKS
35	F15-06000013	半圆键 KEY, WOODRUFF	1	
36	F15-06030000	变档凸轮组件 CAM ASSY, SHIFT ROD	1	L
	F15-06030000S	变档凸轮组件 CAM ASSY, SHIFT ROD	1	S
37	F15-06000020	平面滚针推力轴承 BEARING	1	
38	F15-06000008	小齿轮填隙片 (t: 1.13毫米) SHIM, PINION (t: 1.13MM)	1	
	F15-06000009	小齿轮填隙片 (t: 1.20毫米) SHIM, PINION (t: 1.20MM)	1	
39	F15-06000011	小齿轮 PINION	1	
40	F15-06000012	小齿轮螺母 M8X1 NUT, PINION M8X1	1	

Disassembling and inspection

1. Drain oil, and remove the cotter pin.
2. Put a piece of wood between propeller and anti-swirl baffle. Remove hexagon nut, anode and water inlet.
3. Remove propeller assembly and cushion.
4. Remove anode.
5. Remove the lower casing cover.
Remove reverse gear and shim. Remove oil seal.
6. Remove propeller shaft assembly.
7. Remove shift plunger.
8. Remove clutch ring, remove clutch pin and dog clutch. Remove clutch spring.
9. Remove the drive shaft by using female spline spanner. Remove forward gear.



Female spline spanner

10. Remove drive shaft base.
11. Remove shift rod cam Assy.
12. Remove rolling needle bearing from lower unit.



Rolling needle bearing installer

13. Remove oil seal and barrel bearing with guard board from the drive shaft base.

Propeller shaft and clutch block

1. Check dog clutch for crack or damage. Replace if necessary.
2. Check propeller shaft for wear or crank. Replace if necessary.
3. Check the run out of propeller shaft. If out of specification, replace.

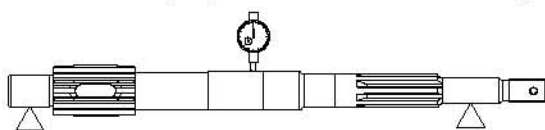

Run out limit: 0.05mm

Dog clutch installation

1. Put clutch spring into the hole at the end of the propeller shaft.
2. Install the dog clutch as shown. Make sure the “F” mark is toward the forward gear. Install clutch pin.

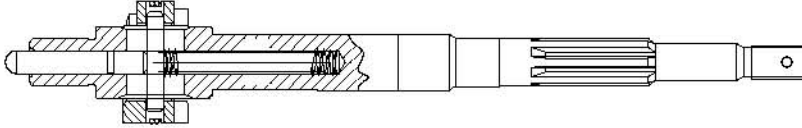

3. Install clutch ring and shift plunger.

Lower casing cover

1. Check bearing for rust or rumbling when run. Replace if necessary.
2. Remove bearing and oil seal by bearing puller.

NOTE:

Don't remove bearing unless changing it.

3. Remove rolling needle bearing by using special tool.

NOTE:

Use new parts when reinstalling the oil seal and rolling needle bearing.

4. Clean casing cover by a soft brush and solvent.
5. Check casing cover for crack or damage. Replace if necessary.

Lower casing cover oil seal and bearing installation

1. Install oil seal.
2. Install bearing.

NOTE:

Install oil seal and bearing by using special tools.

Take note of the direction and depth when installing the oil seal.

Make sure the manufacturer mark of the bearing is toward the reverse gear.



Lower casing cover bearing installer



Lower casing cover barrel bearing installer



Lower casing cover oil seal installer

3. Install reverse gear and shim.

NOTE:

Adjust the shim when install the new reverse gear and bearing.

Drive shaft

1. Inspect the drive shaft for crank or wear. Replace if necessary.
2. Check the run out of drive shaft.

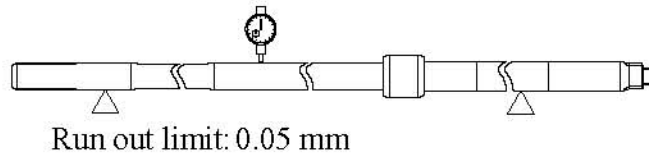

Shift rod cam

Check the shift rod cam for wear or deform. Replace if necessary.

Gear

Inspect the forward gear, reverse gear and pinion for wear or damage. Replace if necessary.

Forward gear bearing

Inspect bearing for rust or rumbling when rotating. Replace if necessary.

NOTE:

Adjust the shim when install new bearing.

Lower casing inspection

Check lower casing for crack or damage, check cooling water inlet for clog. Replace if necessary.

Assembling lower casing

1. Install the rolling needle bearing by using special tool.



Rolling needle bearing installer

2. Install new taper roller bearing (if replace).
3. Install barrel bearing with guard board.
Align the notch on the bearing shoulder with the notch on the drive shaft base.



Bearing block copper sleeve installer

4. Install oil seal.
(unit: mm)



Bearing block oil seal installer

5. Install nylon bushing, shift rod cam assy, gasket, and drive shaft base. Install forward gear, drive shaft, shim, end thrust bearing and pinion.



Forward gear bearing installer

CAUTION:

Adjust shim when install new drive shaft base or drive shaft.

Adjust shim when install new end thrust bearing.

6. Tighten the pinion.
Specified torque: 25 Nm
7. Install propeller shaft assy.
8. Install lower casing cover.
9. Check if gearshift works normally.
10. Install water pump assy.
11. Install anode and water inlet.
12. Install propeller and hexagon nut. Put a piece of wood between propeller and anti-swirl baffle.
Tighten the nut according to specified torque.
Specified torque: 17 Nm

NOTE:

If the nut slot is not aligned with the hole of the propeller shaft cotter pin, tighten the nut until aligned.

Lower unit installation

1. Install dowel pin.
2. Move the shift rod cam assy to reverse gear position. Install the lower unit to upper casing, tighten the bolt according to specified torque.

3. Connect the columned nut and shift rod cam assy. Change shift, and check if the operation is normal. Adjust the columned nut position if necessary. Tighten the nut thoroughly.
4. Add gear oil using the pressure filling device.

Shim selection

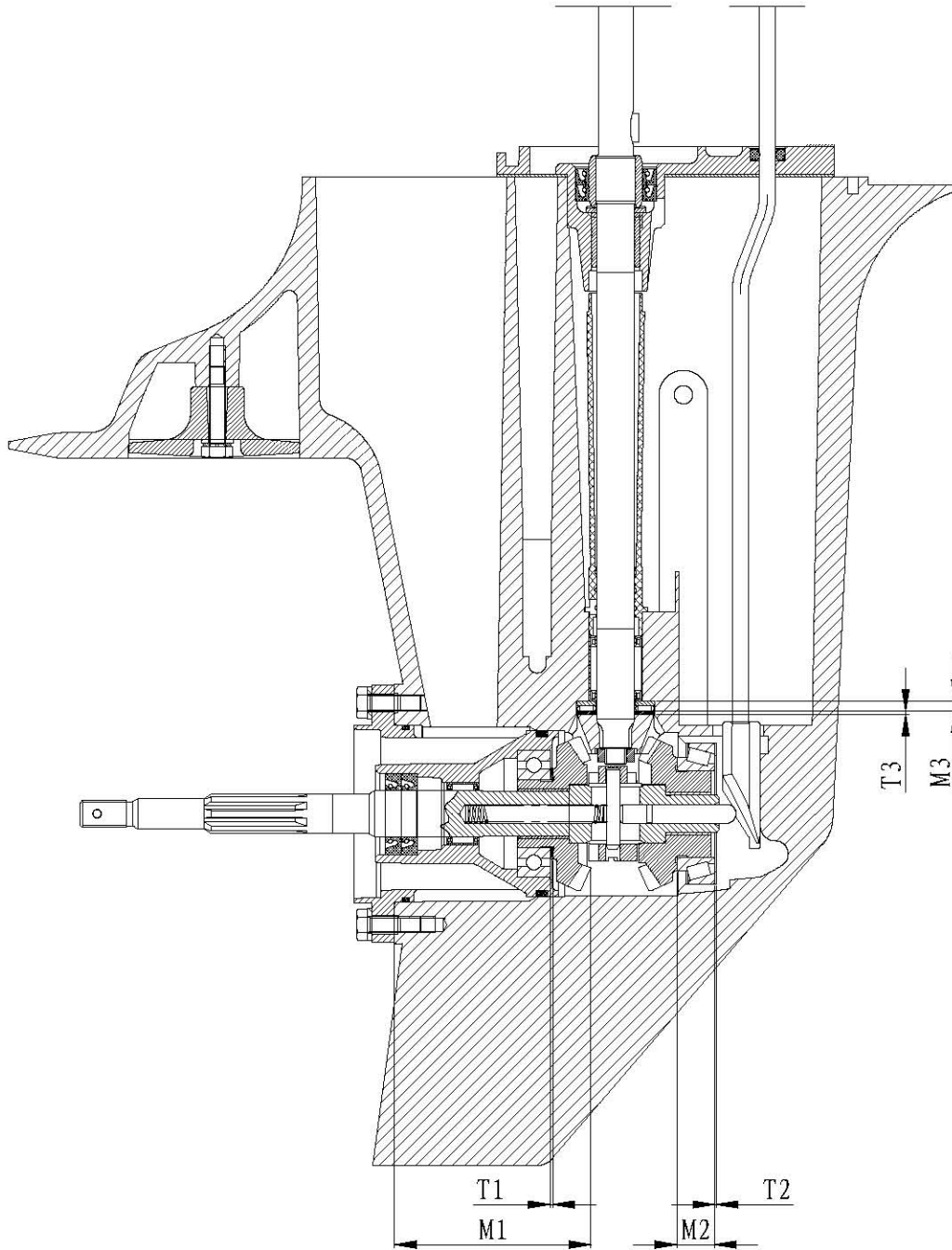

T1、 T2、 T3: Shim thickness

M1: Reverse gear thickness; M2: Forward gear thickness; M3: Thrust rolling needle bearing with flat seat thickness

Calculate formula: $T1=80.57-M1$
 $T2=16.60-M2$
 $T3=6.05-M1$

NOTE:

Use three measuring points when measuring the thickness. Apply the average.
For the optional shim specs, refer to page 11.

COMMON TROUBLES AND SOLUTIONS

Trouble type	Possible reason	Recovery action
Starter will not operate	Starter components are faulty	Repair or replace
	Shift lever is not in the neutral position	Move to the neutral position
Engine will not start	Fuel tank is empty	Fill tank with clean, fresh fuel
	Fuel is contaminated or stale	
	Gasoline cleaner is obstructed	Replace
	Fuel pump is faulty	Inspect or replace
	Air vent screw not loosened	Loosen air vent screw
	Spark plug(s) fouled or of incorrect type.	Inspect spark plug(s). Clean or replace with recommended type
	Spark plug cap(s) fitted incorrectly	Check and re-fit cap(s)
	Ignition wiring is faulty	Check wires. Tighten all loose connections. Replace worn or broken wires
	Ignition parts are faulty	Replace
	Engine stop switch lanyard is not attached	Attach lanyard
	Engine inner parts are damaged	Repair
Engine idles irregularly or stalls	Spark plug(s) fouled or of incorrect type.	Inspect spark plug(s). Clean or replace with recommended type
	Fuel system is obstructed	Check for pinched or kinked fuel line or other obstructions in fuel system
	Fuel is contaminated or stale	Fill tank with clean, fresh fuel
	Fuel cleaner is obstructed	Replace
	Spark plug clearance is incorrect	Inspect and adjust as specified
	Ignition wiring is faulty	Check wires. Tighten all loose connections. Replace worn or broken wires
	Specified engine oil is not being used	Check and replace oil as specified
	Thermostat is faulty	Replace
	Carburetor is faulty	Replace
	Fuel pump is faulty	Replace
	Air vent screw on fuel tank is not loosen	Loosen air vent screw
	Fuel joint connection is incorrect	Connect correctly
	Choke knob is pulled out	Return to home position
Motor angle is too high	Return to normal operating position	

Cont'd

Trouble type	Possible reason	Recovery action
Engine power loss	Propeller is damaged	Repair or replace propeller
	Trim angle is incorrect	Adjust trim angle to achieve most efficient angle
	Motor is mounted at incorrect transom height	Adjust motor to proper transom height
	Boat bottom is fouled with marine growth	Clean boat bottom
	Weeds or other foreign matter are tangled on gear housing	Remove foreign matter and clean lower unit
	Spark plug(s) fouled or of incorrect type.	Inspect spark plug(s). Clean or replace with recommended type
	Fuel system is obstructed	Check for pinched or kinked fuel line or other obstructions in fuel system
	Fuel cleaner is obstructed	Replace
	Fuel is contaminated or stale	Fill tank with clean, fresh fuel
	Spark plug clearance is incorrect	Inspect and adjust as specified
	Ignition wiring is faulty	Check wires. Tighten all loose connections. Replace worn or broken wires
	Ignition parts have failed	Replace
	Specified engine oil is not being used or oil is added too much	Check and replace oil as specified, or adjust engine oil to specified position
	Thermostat is faulty	Replace
	Fuel pump is faulty	Replace
Fuel joint connection is incorrect	Connect correctly	
Specified spark plug(s) are not being used	Check and replace spark plug(s) as specified	
Engine vibrates excessively	Propeller is damaged	Repair or replace propeller
	Propeller shaft is damaged	Replace
	Weeds or other foreign matter are tangled on propeller	Remove and clean propeller
	Motor mounting bolt is loose	Tighten bolt
	Steering pivot is loose	Tighten steering pivot
	Steering pivot is damaged	Replace